

Issue No. 19

October 2018

The ASPE OC PRESS



President's Message

by Saum K. Nour, Ph.D.

Page 2

ASPE Membership

American Society of Plumbing Engineers

Membership Application

Page 13

ASPE Convention & Expo Delegate Report

Page 37

PRESIDENT'S MESSAGE

By Saum K. Nour, Ph.D.

Greetings,

To all members of ASPE Orange County, California.

Technical Meeting (!! New Location for this meeting!!)

Date: October 23, 2018

Time: 5:30 PM to 7:00 PM – Social Hour

Time: 7:00 PM to 9:00 PM – Main Speaker

The Phoenix Club

1340 S. Sanderson Ave

Anaheim, CA 92806

Admission (Dinner included):

RSVP: \$ 40.00 per person – [Click to complete RSVP only form](#)

Credit Card: \$ 34.00 per person – [Click to view product and add to cart on ASPEOC website](#)

At Meeting: \$ 40.00 Cash

ADVERTISE IN THE ASPE ORANGE COUNTY NEWSLETTER!

- Support your business
- Great way to network with people in your industry
- Support your local ASPE chapter

LOCAL CHAPTERS ARE NOT ALLOWED TO SPEAK FOR THE SOCIETY!

NEWSLETTER SPONSORSHIP AGREEMENT

Sponsor's Name: _____,

Address: _____,

Contact Person: _____ Phone No.: _____, _____

Type of sponsorship selected:

(MONTHLY RATES)

Business Card (\$25) 1/4" Page (\$40) 1/2 Page (\$75) Full Page (\$115)

(YEARLY RATES)

Business Card (\$120) newsletter only Business Card (\$200) includes Sponsor page link

1/4" Page (\$250) 1/2 Page (\$450) Full Page (\$800)

Partial year sponsorship will be provided. Make checks payable to: **ASPE** at the above address. Sponsors must provide their own electronic artwork files (jpeg, gif, bmp etc..).

Sponsorship Signature: _____,

ASPE Signature: _____,

PRESIDENT'S MESSAGE

At Meeting: \$ 40.00 Credit Card

Tonight's presenter and topic:

Seismic Bracing & Best Practices To Ensure Code Compliance With Current Standards

Ladies and gentlemen, we are pleased to announce that our next Technical Meeting will be on October 23d, 2018.

We will be having Brent Mullen, P.E. – Engineering Manager for AJ Engineering presenting.

This presentation on seismic bracing will discuss system requirements and best practices necessary to ensure code compliance with the most current standards. Attendees should be able to identify specific components requiring seismic design after attending this presentation. No prior knowledge of seismic design is required to attend.

Brent Mullen, P.E. – Engineering Manager for AJ Engineering. Registered professional mechanical engineering in California with over 5 years of experience in seismic design for mechanical, electrical, plumbing, and fire protection systems working with various seismic bracing manufacturers and engineering companies.

Topics Covered:

- Comparison of past and present building codes – 2010, 2013, and 2016 CBC
- General seismic bracing requirements for mechanical and plumbing systems
- Overview of Mason West OPM-0043-13
- Requirements and potential difficulties when working on projects under OSHPD and DSA
- Examples of seismic engineering submittals

Anyone that is involved in any form of seismic bracing design should attend this event. This is a Must-See-Presentation.

Please join us at our technical meeting to learn more about this topic. Your suggestions for topics and technical speakers are welcomed; please speak to anyone on the ASPE-OC Board.

ANNOUNCEMENTS:

Tables app for iOS is now available

ASPE's popular Tables Book App-a free member benefit-offers in one convenient place all of the equations, pipe sizing data, and background information that you need to successfully complete plumbing system design and installation projects on a daily basis. A new desktop version also will be released soon.

ASPE seeks members to join our Mentoring Program

Do you want to help nurture the next generation of plumbing designers and engineers? ASPE currently is in need of Mentors with the following credentials: Certified in Plumbing Design (CPD), Certified Plumbing Design Technician (CPDT), and Green Plumbing Design (GPD). To learn more and sign up, visit aspe.org/aspe-mentoring-program.

PRODUCT SHOWCASE and CPD Class:

Please join us at 5:30 pm for the one and only CPD preparation class in ASPE Region 4. This class is presented by Dr. Saum K. Nour, Ph.D, P.E., LEED AP, AIA, CPD of Absolute Consulting Engineers.

Tabletop Presentation: Available.

Please RSVP by 5 pm October 19th, 2018 to: info@aspeoc.com as an accurate head count will help us put on an efficient program.

Sincerely,

Dr. "Saum" K. Nour, Ph.D.

PE Mechanical, PE Electrical, PE Civil, CPD, ASPE Fellow, LEED AP, CFPE

Acting President

Chapter 6: Plumbing Elements and Facilities

601 General

601.1 Scope. The provisions of Chapter 6 shall apply where required by Chapter 2 or where referenced by a requirement in this document.

602 Drinking Fountains

602.1 General. Drinking fountains shall comply with 307 and 602.

602.2 Clear Floor Space. Units shall have a clear floor or ground space complying with 305 positioned for a forward approach and centered on the unit. Knee and toe clearance complying with 306 shall be provided.

EXCEPTION: A parallel approach complying with 305 shall be permitted at units for children's use where the spout is 30 inches (760 mm) maximum above the finish floor or ground and is 3½ inches (90 mm) maximum from the front edge of the unit, including bumpers.

602.3 Operable Parts. Operable parts shall comply with 309.

602.4 Spout Height. Spout outlets shall be 36 inches (915 mm) maximum above the finish floor or ground.

602.5 Spout Location. The spout shall be located 15 inches (380 mm) minimum from the vertical support and 5 inches (125 mm) maximum from the front edge of the unit, including bumpers.

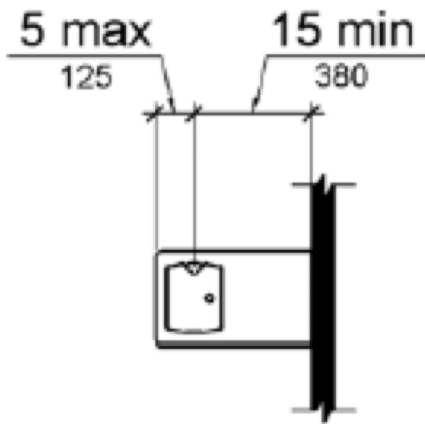

Figure 602.5 Drinking Fountain Spout Location

602.6 Water Flow. The spout shall provide a flow of water 4 inches (100 mm) high minimum and shall be located 5 inches (125 mm) maximum from the front of the unit. The angle of the water stream shall be measured horizontally relative to the front face of the unit. Where spouts are located less than 3 inches (75 mm) of the front of the unit, the angle of the water stream shall be 30 degrees maximum. Where spouts are located between 3 inches (75 mm) and 5 inches (125 mm) maximum from the front of the unit, the angle of the water stream shall be 15 degrees maximum.

Advisory 602.6 Water Flow. The purpose of requiring the drinking fountain spout to produce a flow of water 4 inches (100 mm) high minimum is so that a cup can be inserted under the flow of water to provide a drink of water for an individual who, because of a disability, would otherwise be incapable of using the drinking fountain.

602.7 Drinking Fountains for Standing Persons. Spout outlets of drinking fountains for standing persons shall be 38 inches (965 mm) minimum and 43 inches (1090 mm) maximum above the finish floor or ground.

603 Toilet and Bathing Rooms

603.1 General. Toilet and bathing rooms shall comply with 603.

603.2 Clearances. Clearances shall comply with 603.2.

603.2.1 Turning Space. Turning space complying with 304 shall be provided within the room.

603.2.2 Overlap. Required clear floor spaces, clearance at fixtures, and turning space shall be permitted to overlap.

603.2.3 Door Swing. Doors shall not swing into the clear floor space or clearance required for any fixture. Doors shall be permitted to swing into the required turning space.

EXCEPTIONS: 1. Doors to a toilet room or bathing room for a single occupant accessed only through a private office and not for common use or public use shall be permitted to swing into the clear floor space or clearance provided the swing of the door can be reversed to comply with 603.2.3.

2. Where the toilet room or bathing room is for individual use and a clear floor space complying with 305.3 is provided within the room beyond the arc of the door swing, doors shall be permitted to swing into the clear floor space or clearance required for any fixture.

Advisory 603.2.3 Door Swing Exception 1. At the time the door is installed, and if the door swing is reversed in the future, the door must meet all the requirements specified in 404. Additionally, the door swing cannot reduce the required width of an accessible route. Also, avoid violating other building or life safety codes when the door swing is reversed.

603.3 Mirrors. Mirrors located above lavatories or countertops shall be installed with the bottom edge of the reflecting surface 40 inches (1015 mm) maximum above the finish floor or ground. Mirrors not located above lavatories or countertops shall be installed with the bottom edge of the reflecting surface 35 inches (890 mm) maximum above the finish floor or ground.

Advisory 603.3 Mirrors. A single full-length mirror can accommodate a greater number of people, including children. In order for mirrors to be usable by people who are ambulatory and people who use wheelchairs, the top edge of mirrors should be 74 inches (1880 mm) minimum from the floor or ground.

603.4 Coat Hooks and Shelves. Coat hooks shall be located within one of the reach ranges specified in 308. Shelves shall be located 40 inches (1015 mm) minimum and 48 inches (1220 mm) maximum above the finish floor.

604 Water Closets and Toilet Compartments

604.1 General. Water closets and toilet compartments shall comply with 604.2 through 604.8.

EXCEPTION: Water closets and toilet compartments for children's use shall be permitted to comply with 604.9.

604.2 Location. The water closet shall be positioned with a wall or partition to the rear and to one side. The centerline of the water closet shall be 16 inches (405 mm) minimum to 18 inches (455 mm) maximum from the side wall or partition, except that the water closet shall be 17 inches (430 mm) minimum and 19 inches (485 mm) maximum from the side wall or partition in the ambulatory accessible toilet compartment specified in 604.8.2. Water closets shall be arranged for a left-hand or right-hand approach.

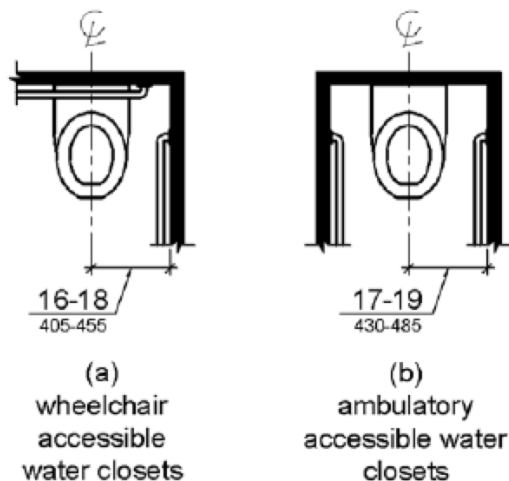

Figure 604.2 Water Closet Location

604.3 Clearance. Clearances around water closets and in toilet compartments shall comply with 604.3.

604.3.1 Size. Clearance around a water closet shall be 60 inches (1525 mm) minimum measured perpendicular from the side wall and 56 inches (1420 mm) minimum measured perpendicular from the rear wall.

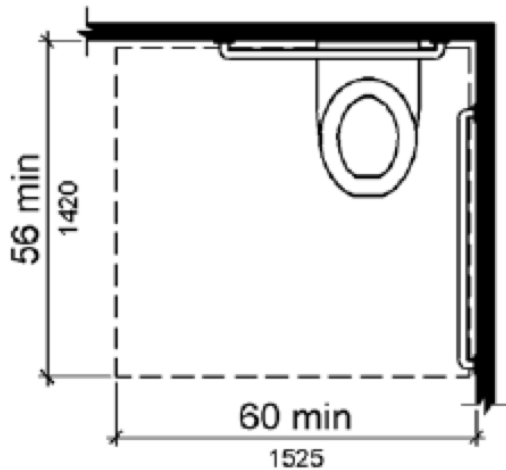

Figure 604.3.1 Size of Clearance at Water Closets

604.3.2 Overlap. The required clearance around the water closet shall be permitted to overlap the water closet, associated grab bars, dispensers, sanitary napkin disposal units, coat hooks, shelves, accessible routes, clear floor space and clearances required at other fixtures, and the turning space. No other fixtures or obstructions shall be located within the required water closet clearance. EXCEPTION: In residential dwelling units, a lavatory complying with 606 shall be permitted on the rear wall 18 inches (455 mm) minimum from the water closet centerline where the clearance at the water closet is 66 inches (1675 mm) minimum measured perpendicular from the rear wall.

Advisory 604.3.2 Overlap. When the door to the toilet room is placed directly in front of the water closet, the water closet cannot overlap the required maneuvering clearance for the door inside the room.

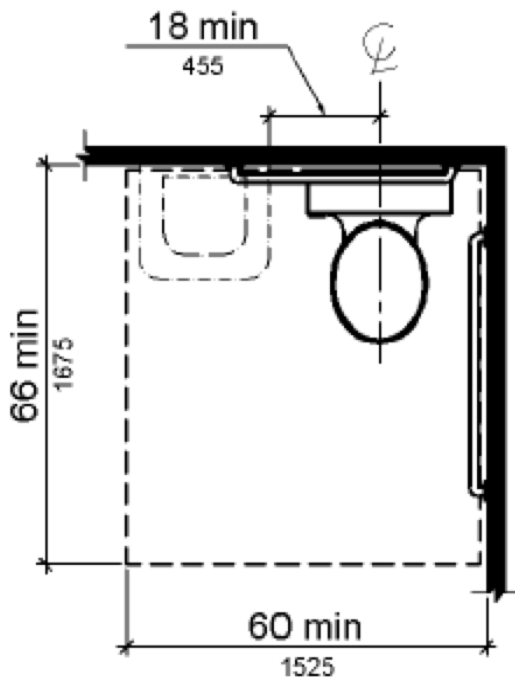

Figure 604.3.2 (Exception) Overlap of Water Closet Clearance in Residential Dwelling Units

604.4 Seats. The seat height of a water closet above the finish floor shall be 17 inches (430 mm) minimum and 19 inches (485 mm) maximum measured to the top of the seat. Seats shall not be sprung to return to a lifted position.

EXCEPTIONS: 1. A water closet in a toilet room for a single occupant accessed only through a private office and not for common use or public use shall not be required to comply with 604.4.



Delta-Q Inc.

1851 Dawns Way
Fullerton, CA 92831
714-879-0622...Fax 714-879-0623
www.deltaginc.com

Manufacturer's Representatives of Pumps, Plumbing, HVAC, Luxury



Residential & Commercial High Quality
Pumps and Pumping Systems
www.us.grundfos.com



Complete Line of Faucets and Fixtures,
Residential and Commercial
www.americanstandard-us.com



Bath & Ventilation Fans, Range Hoods, Fresh Air Systems,
Attic Ventilation, Trash Compactors
www.broan.com



Water Storage, Treatment, Heating,
Expansion, & Flow Control
www.amtrol.com



Full Line of Water Filtration System and
Filters, New and Replacement
www.falskenwatersystems.com



Bath & Ventilation Fans, Range Hoods, Intercom, Home
Automation, Central Vac, Door Chimes
www.nutone.com



On Demand Hot Water
Systems and Pump
Controls

www.gothotwater.com



Water Soluble Flux, Tankless Clense Kits,
Non Toxic Drain Cleaner
www.deltaginc.com



Gas Heating Equipment, Wholesale Only
www.cozyheaters.com



Sump, Sewage, Basins, Grinders and
Packaged Pump Systems
www.cranepumps.com/brands/Barnes.php



Tubular, Angle Stops, Basket Strainers, ADA
Grab Bars, Master Kits
www.keeneymfg.com



Tankless Elec Hot Water Solutions, Space
Heating & Restroom Products
www.stiebel-eltron-usa.com



Professional Torch Equipment
www.gossonline.com



Durable Shower Solutions including Bases,
Laundry Sinks, ADA Showers
www.fiatproducts.com



Radiant Heating and Cooling Systems
www.rehau.com/us-en/mechanical-and-plumbing



Thermostatic Mixing Valves Tempered
Water Soutions
www.lawlervalue.com



Walk In Tubs for the Assisted Living Market
www.safetytubs.com



Industrial Instrumentation, Pressure
Gauges, Thermometers
www.winters.com



Emergency Eyewash & Showering
Valves
www.tepid.com



Food Waste Disposers, Insta Hot, Water
Chillers
www.mountainplumbing.com

2. In residential dwelling units, the height of water closets shall be permitted to be 15 inches (380 mm) minimum and 19 inches (485 mm) maximum above the finish floor measured to the top of the seat.

604.5 Grab Bars. Grab bars for water closets shall comply with 609. Grab bars shall be provided on the side wall closest to the water closet and on the rear wall.

EXCEPTIONS: 1. Grab bars shall not be required to be installed in a toilet room for a single occupant accessed only through a private office and not for common use or public use provided that reinforcement has been installed in walls and located so as to permit the installation of grab bars complying with 604.5.

2. In residential dwelling units, grab bars shall not be required to be installed in toilet or bathrooms provided that reinforcement has been installed in walls and located so as to permit the installation of grab bars complying with 604.5.

3. In detention or correction facilities, grab bars shall not be required to be installed in housing or holding cells that are specially designed without protrusions for purposes of suicide prevention.

Advisory 604.5 Grab Bars Exception 2. Reinforcement must be sufficient to permit the installation of rear and side wall grab bars that fully meet all accessibility requirements including, but not limited to, required length, installation height, and structural strength.

604.5.1 Side Wall. The side wall grab bar shall be 42 inches (1065 mm) long minimum, located 12 inches (305 mm) maximum from the rear wall and extending 54 inches (1370 mm) minimum from the rear wall.

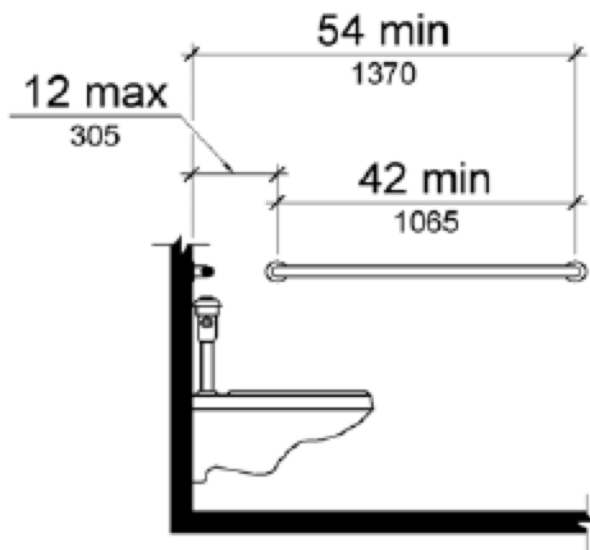

Figure 604.5.1 Side Wall Grab Bar at Water Closets

604.5.2 Rear Wall. The rear wall grab bar shall be 36 inches (915 mm) long minimum and extend from the centerline of the water closet 12 inches (305 mm) minimum on one side and 24 inches (610 mm) minimum on the other side.

EXCEPTIONS: 1. The rear grab bar shall be permitted to be 24 inches (610 mm) long minimum, centered on the water closet, where wall space does not permit a length of 36 inches (915 mm) minimum due to the location of a recessed fixture adjacent to the water closet.

2. Where an administrative authority requires flush controls for flush valves to be located in a position that conflicts with the location of the rear grab bar, then the rear grab bar shall be permitted to be split or shifted to the open side of the toilet area.

Your Premier Providers of Life, Property and Asset Protection Solutions

CLEAN AGENT FIRE SUPPRESSION

Our fire protection specialists bring you the finest in fire protection, including the most cost effective to the most environmentally green products available. Fike's **ECARO-25**® (using DuPont™ FE-25™ as the fire-extinguishing agent) is the best, most cost-effective clean agent system available. We offer a full line of leading-edge systems for a variety of applications:

- Cost-Effective Clean Agent Systems
- Green Inert Gas Systems
- Drop-in Halon Replacement
- In Cabinet / Small-Space Protection
- CO₂ Systems



FIRE ALARM AND LIFE SAFETY

Our code-compliant fire alarm systems with specialty detection utilize high quality equipment from industry-leading manufacturers. We have extensive experience in projects from small commercial buildings, to large high-rise facilities, to sprawling industrial complexes. Our NICET certified sales team, designers, project managers, and technicians strive to exceed our client expectations.



- Addressable, Conventional, and Networked Fire Alarm Systems
- Voice Evacuation
- Linear Heat Detection
- Air Sampling
- Pre-action Sprinkler Detection & Control



EMERGENCY POWER SHUTDOWN MANAGEMENT SYSTEM (EPSMS)

Fike's Emergency Power Shutdown Management System (EPSMS) is designed to consolidate and control equipment emergency power off in a timely, efficient and coordinated manner. EPSMS is used in many applications to:

- De-energize equipment during a fire
- Close fire dampers and turn off HVAC to contain fire and maintain proper concentration of fire suppressant
- Safely shutdown equipment during a flood or sprinkler system discharge
- Help protect fire department personnel from electrocution when fighting a fire



Call today for your life safety evaluation.



FACILITIES PROTECTION SYSTEMS

714-257-2244

www.fpsys.com



925-484-3701

www.gotoitsi.com

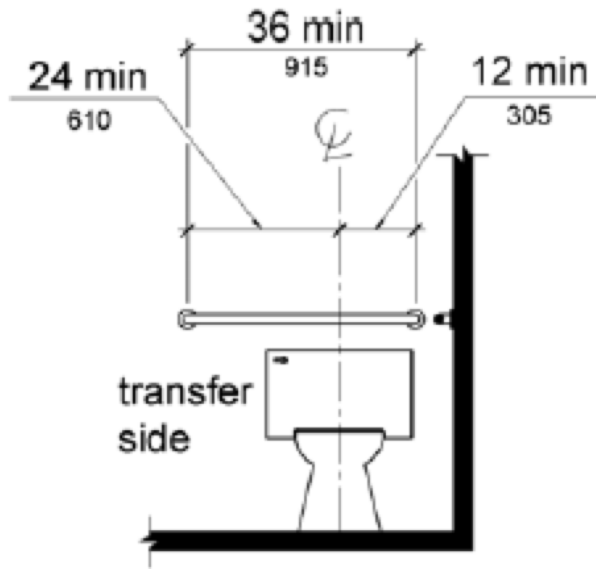

Figure 604.5.2 Rear Wall Grab Bar at Water Closets

604.6 Flush Controls. Flush controls shall be hand operated or automatic. Hand operated flush controls shall comply with 309. Flush controls shall be located on the open side of the water closet except in ambulatory accessible compartments complying with 604.8.2.

Advisory 604.6 Flush Controls. If plumbing valves are located directly behind the toilet seat, flush valves and related plumbing can cause injury or imbalance when a person leans back against them. To prevent causing injury or imbalance, the plumbing can be located behind walls or to the side of the toilet; or if approved by the local authority having jurisdiction, provide a toilet seat lid.

604.7 Dispensers. Toilet paper dispensers shall comply with 309.4 and shall be 7 inches (180 mm) minimum and 9 inches (230 mm) maximum in front of the water closet measured to the centerline of the dispenser. The outlet of the dispenser shall be 15 inches (380 mm) minimum and 48 inches (1220 mm) maximum above the finish floor and shall not be located behind grab bars. Dispensers shall not be of a type that controls delivery or that does not allow continuous paper flow.

Advisory 604.7 Dispensers. If toilet paper dispensers are installed above the side wall grab bar, the outlet of the toilet paper dispenser must be 48 inches (1220 mm) maximum above the finish floor and the top of the gripping surface of the grab bar must be 33 inches (840 mm) minimum and 36 inches (915 mm) maximum above the finish floor.

Plumbing Design Engineer's : Orange County, San Diego and San Jose available positions at all levels.

We are looking for a team players! We are looking for a motivated, team-oriented, collaborative leader to support the growth of our fast-developing Plumbing team. This person would play a key plumbing engineering group and would be responsible for delivery of technical engineering work.
Key Responsibilities: The Plumbing Engineer is responsible for performing complex design calculations, sketches, technical comparisons and similar technical work as required by assignment. Designs complete systems (e.g. water hot and cold systems, waste and vent, storm drainage, natural gas, fuel oil, controls, medical gases) for low through mid-rise projects. In addition, the engineer calculates and understands impacting issues in Title-24 compliance.

Typical Duties:

- Performs more complex design calculations, sketches, technical comparisons and similar technical work as required by assignment / direction by Project Manager.
- Performs coordination at a higher level by reviewing drawings supplied by vendors, other team engineers, and the architects and implements design modifications as necessary.
- Researches code issues as directed by the Project Manager.
- Researches design options and discuss findings with Project Managers.
- Proficiency in the use of 2D/3D software, including AutoCAD 2D, AutoCAD 3D, Revit, and Navisworks.
- Proficient computer skills with programs such as Word, Excel, PowerPoint, and Microsoft Project Experience performing site investigations of existing building system for renovation type projects.
- Visiting jobsites during construction phase and identifying and generally confirming the proper installation of designed systems and equipment.
- Communicating with and utilizing subordinates (e.g. CAD/BIM manual drafting and Design personnel) in the preparation and/or completion of design documents.
- Communicating with architects and other consultants regarding building systems and their impact on the system design.
- Communicating with building officials regarding code issues impacting system design.
- Begin to interact with clients as his or her level of experience progresses. May attend "kick-off" and design review meetings as directed by a Project Manager.
- Reviewing project budget cost and preparing opinions of probable construction costs.

Qualifications: Bachelor's Degree in Engineering or Related field is preferred.

- 5 - 7 years of project experience in Plumbing design.
- Experience with AutoCAD and Revit is required.
- Knowledge of California Plumbing Code and related California Building Codes.
- Knowledge of green building practices and LEED Rating System.
- LEED AP Certification is desired.
- Experience with healthcare plumbing systems and life science projects are desirable. (OSHPD)

Nancy Whitley

nwhitley@healthcarentalent.net

949-709-1883x 232



Stay connected with Viega
Secure, proven solutions
for joining pipe

viega.us

At Viega, we are an industry leader that is connected to our customers. Every day, we develop products that change the way engineers and mechanical contractors do business. It's our job to engineer forward-thinking products, including Viega MegaPress® and MegaPressG for black iron pipe, Viega ProPress® for copper and stainless steel, Viega PEX Press for potable and reclaimed water, as well as heating and cooling systems. Viega systems help you make product decisions that meet your qualifications and the end users' expectations. Choose Viega and help us bring press technology to the masses. **Viega. Connected in quality.**

viega

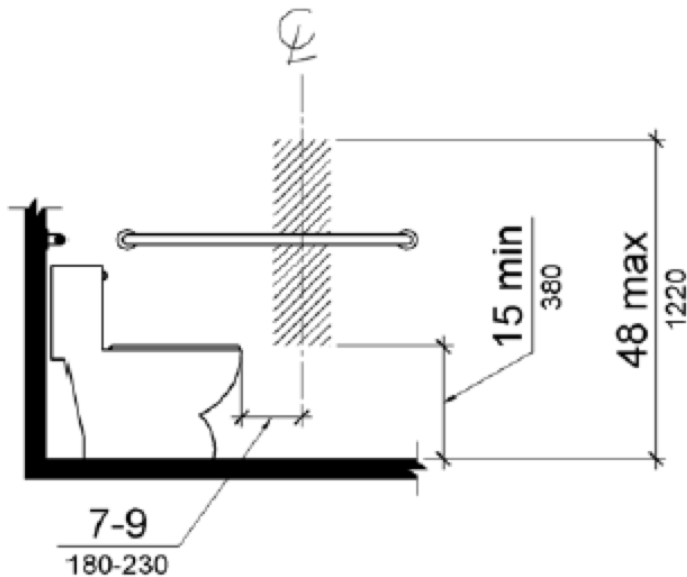

Figure 604.7 Dispenser Outlet Location

604.8 Toilet Compartments. Wheelchair accessible toilet compartments shall meet the requirements of 604.8.1 and 604.8.3. Compartments containing more than one plumbing fixture shall comply with 603. Ambulatory accessible compartments shall comply with 604.8.2 and 604.8.3.

604.8.1 Wheelchair Accessible Compartments. Wheelchair accessible compartments shall comply with 604.8.1.

604.8.1.1 Size. Wheelchair accessible compartments shall be 60 inches (1525 mm) wide minimum measured perpendicular to the side wall, and 56 inches (1420 mm) deep minimum for wall hung water closets and 59 inches (1500 mm) deep minimum for floor mounted water closets measured perpendicular to the rear wall. Wheelchair accessible compartments for children's use shall be 60 inches (1525 mm) wide minimum measured perpendicular to the side wall, and 59 inches (1500 mm) deep minimum for wall hung and floor mounted water closets measured perpendicular to the rear wall.

Advisory 604.8.1.1 Size. The minimum space required in toilet compartments is provided so that a person using a wheelchair can maneuver into position at the water closet. This space cannot be obstructed by baby changing tables or other fixtures or conveniences, except as specified at 604.3.2 (Overlap). If toilet compartments are to be used to house fixtures other than those associated with the water closet, they must be designed to exceed the minimum space requirements. Convenience fixtures such as baby changing tables must also be accessible to people with disabilities as well as to other users. Toilet compartments that are designed to meet, and not exceed, the minimum space requirements may not provide adequate space for maneuvering into position at a baby changing table.

MEMBERSHIP APPLICATION
(Please Print or Type)



American Society of Plumbing Engineers

6400 Shafer Court, Suite 350 | Rosemont, IL 60018
(847) 296-0002 | Fax: (847) 296-2963 | www.aspe.org | aspehq@aspe.org

Chapter Use Only

H	
Q	
N	
O	
7	

Promo CODE: MBR2011

INCOMPLETE APPLICATIONS WILL NOT BE PROCESSED.

Mr. Ms. Miss Mrs.

First Name _____ (Nickname) _____ Middle Name _____ Last Name _____

Birth Date: M ___ /D ___ /Y ___ Check all that apply: P.E. P. Eng CPD Graduate Engineer LEED AP CET Other _____

I wish to affiliate with the _____ Chapter. Certification (P.E.) State _____ Certificate No. _____ Branch _____

Preferred Mailing Address RESIDENCE BUSINESS

RESIDENCE: Street Address _____ City _____ State _____ ZIP _____ Phone _____

E-mail (required) _____ Business E-mail _____ Cell Phone _____

BUSINESS: Organization Name _____ Your Title _____ Phone _____

Street Address _____ City _____ State _____ ZIP _____ Fax _____

Other organizations you are a member of: ASHRAE ASSE NFPA NSPE ASME PHCC ICC IAPMO SFPE Other _____

EDUCATION

	Name of Institution	Course or Major	From	To	Graduation Date	Degree/Diploma
High School						
College/University						
Technical School						
Others						

PROFESSIONAL EXPERIENCE

(This section must be completed as it affects membership grade classification. List chronologically, beginning with the present. Work description must be clear and concise: e.g., plumbing, piping, fire protection, HVAC, etc. Use additional sheet as necessary.)

Date(Mo/Yr)	Firm Name and Address	Class* (see below)	Title	Description of Work	Degree of Responsibility
From To					

*Classification of Firm A - Arch./Engr. or Cons. Engr. B - Govt. Agency C - Mfr. or Mfr's. Rep. D - Educ. Inst. E - Contractor F - Other (Explain)

REFERENCES

(References should be in engineering profession. ASPE members preferred. ASPE reserves the right to contact references.)

Name	Address	Telephone

PLUMBING ENGINEERING DESIGN HANDBOOK

New members receive one of four volumes of the this definitive collection of general plumbing practices. As an ASPE member you will be sent the CD-rom unless you indicate preference for the softcover edition. If you would like both the CD-rom and softcover editions, please add \$50 to your total to the right.

CD-ROM SOFTCOVER

RENEWAL REMINDER

I WOULD LIKE TO RECEIVE MEMBERSHIP RENEWAL REMINDERS AND SOCIETY RELATED IMPORTANT ANNOUNCEMENTS VIA TEXT MESSAGES.

CERTIFICATION BY APPLICANT

The undersigned certifies that all statements made herein are correct and, if elected to the Society, agrees to adhere to the Society's Bylaws and accept the Classification conferred by the Society. Upon becoming a member, the applicant will endeavor to advance the objectives of the Society and the plumbing engineering profession.

Signature of Applicant _____ Date _____

Sponsor _____ (Please Print)

How did you hear about ASPE? Past Member Plumbing Engineer Magazine Colleague/Employer ASPE App Website Other _____

American Society of Plumbing Engineers member dues are nonrefundable and not deductible as a charitable expense, but may be deductible as a business expense.

* Contributions to ASPE Education (create education programs for membership) and Alfred Steele Scholarship (to award college scholarships) and PE Curriculum/Licensing (create future curriculum and licensing opportunities for membership) Funds are Strictly Voluntary and are not deductible as a charitable contribution but may be deductible as an ordinary and necessary business expense.

** Contributions to the ASPE Research Foundation are Strictly Voluntary and are tax deductible as a charitable contribution.

© Copyright 2016 American Society of Plumbing Engineers. All Rights Reserved.

REMIT MEMBERSHIP DUES WITH APPLICATION

Member Type	Amount	Amount Due
<input type="checkbox"/> Full	\$190	\$ _____
<input type="checkbox"/> Associate	\$170	\$ _____
<input type="checkbox"/> Affiliate	\$190	\$ _____
<input type="checkbox"/> Special	\$190	\$ _____
<input type="checkbox"/> Governmental	\$190	\$ _____
<input type="checkbox"/> Student	\$30	\$ _____
<input type="checkbox"/> PEDH CD & Book	\$50	\$ _____
<input type="checkbox"/> ASPE Alfred Steele Scholarship Fund*	\$25	\$ _____
<input type="checkbox"/> ASPE Education Program Fund*	\$25	\$ _____
<input type="checkbox"/> PE Curriculum/Licensure Fund*	\$25	\$ _____
<input type="checkbox"/> ASPE Research Foundation**	\$25	\$ _____

TOTAL AMOUNT DUE \$ _____

Payment Information:

Enclosed is my check payable to ASPE.

Please charge my: Visa, MasterCard Discover

American Express

Card # _____

Exp Date: _____

Signature: _____

Date: _____ Telephone: _____

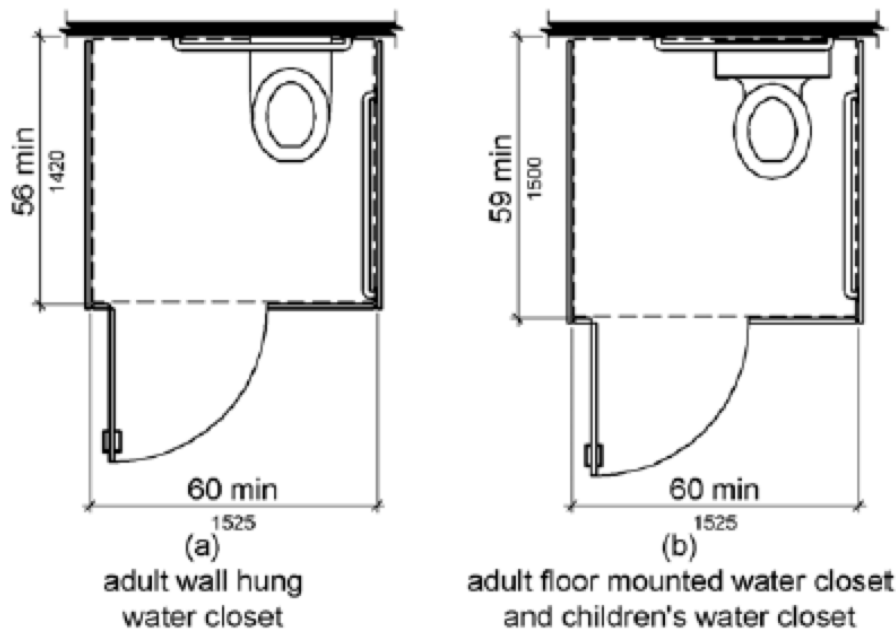

Figure 604.8.1.1 Size of Wheelchair Accessible Toilet Compartment

604.8.1.2 Doors. Toilet compartment doors, including door hardware, shall comply with 404 except that if the approach is to the latch side of the compartment door, clearance between the door side of the compartment and any obstruction shall be 42 inches (1065 mm) minimum. Doors shall be located in the front partition or in the side wall or partition farthest from the water closet. Where located in the front partition, the door opening shall be 4 inches (100 mm) maximum from the side wall or partition farthest from the water closet. Where located in the side wall or partition, the door opening shall be 4 inches (100 mm) maximum from the front partition. The door shall be self-closing. A door pull complying with 404.2.7 shall be placed on both sides of the door near the latch. Toilet compartment doors shall not swing into the minimum required compartment area.

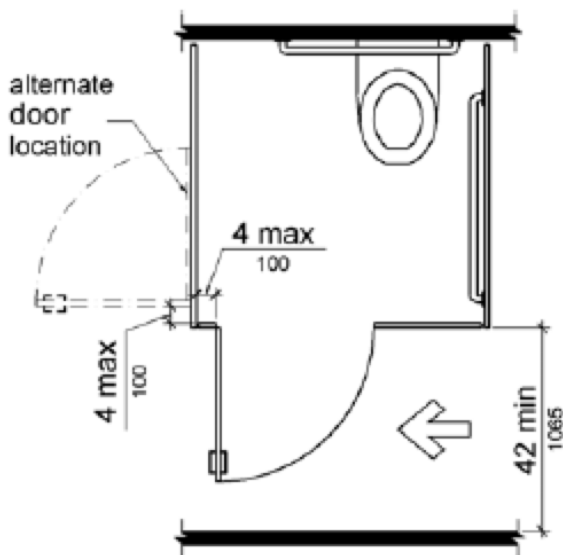

Figure 604.8.1.2 Wheelchair Accessible Toilet Compartment Doors

604.8.1.3 Approach. Compartments shall be arranged for left-hand or right-hand approach to the water closet.

604.8.1.4 Toe Clearance. The front partition and at least one side partition shall provide a toe clearance of 9 inches (230 mm) minimum above the finish floor and 6 inches (150 mm) deep minimum beyond the compartment-side face of the partition, exclusive of partition support members. Compartments for children's use shall provide a toe clearance of 12 inches (305 mm) minimum above



NewAge Casting

Welcome to the New Age.

Certified by



Welcome to the NewAge of Epoxy Soil Pipe

APPLICATIONS

Medical Facilities

Hospitals, Trauma Centers, Laboratories, Dialysis Clinics, Research Facilities

Enhanced DWV

Kitchens, Bars, Soda Machines, Grease Interceptors, Waterless Urinals, High Efficiency, Casinos

Destructive Elements & Environments

Maritime, Corrosive Soils, Rainwater, Boiler Rooms, Sustainable Buildings with waste volumes flowing from 20% to 50% less

High Occupancy Structures

High Rises, Malls, Shopping Centers, Schools, Colleges, Universities, Arenas, Stadiums, Theatres, Convention Centers, Office Complexes

Assisted Living Centers

Convalescent Homes, MOBs

COST

A cost effective alternative to CPVC, acid waste, glass pipe, duriron, & stainless steel. We offer a solution to existing pipe materials, sizes & specifications.

EPOXY COATING TESTING

1. Salt Spray
2. Chemical
3. High temperature waste testing
4. Temperature cycling testing
5. Flame resistant

INSTALLATION

Standard installation practices

PRODUCTS

No Hub from 1-1/2" to 15" & Couplings

SPECIFICATION & STANDARDS

ASTM - A888

CISPI 301

ASTM 1277, 1540 & C564 - Regular & HD Couplings

EN 877 Coating Specification & Testing



For the life of the building.

12630 West Airport Blvd. • Suite 100
Sugar Land, TX 77478 • Phone: (281)565-0928
Fax: (281)565-0929 • Email: info@NewAgeCasting.com

Toll Free: 1.866.791.7055 • NewAgeCasting.com

the finish floor.

EXCEPTION: Toe clearance at the front partition is not required in a compartment greater than 62 inches (1575 mm) deep with a wall-hung water closet or 65 inches (1650 mm) deep with a floor-mounted water closet. Toe clearance at the side partition is not required in a compartment greater than 66 inches (1675 mm) wide. Toe clearance at the front partition is not required in a compartment for children's use that is greater than 65 inches (1650 mm) deep.

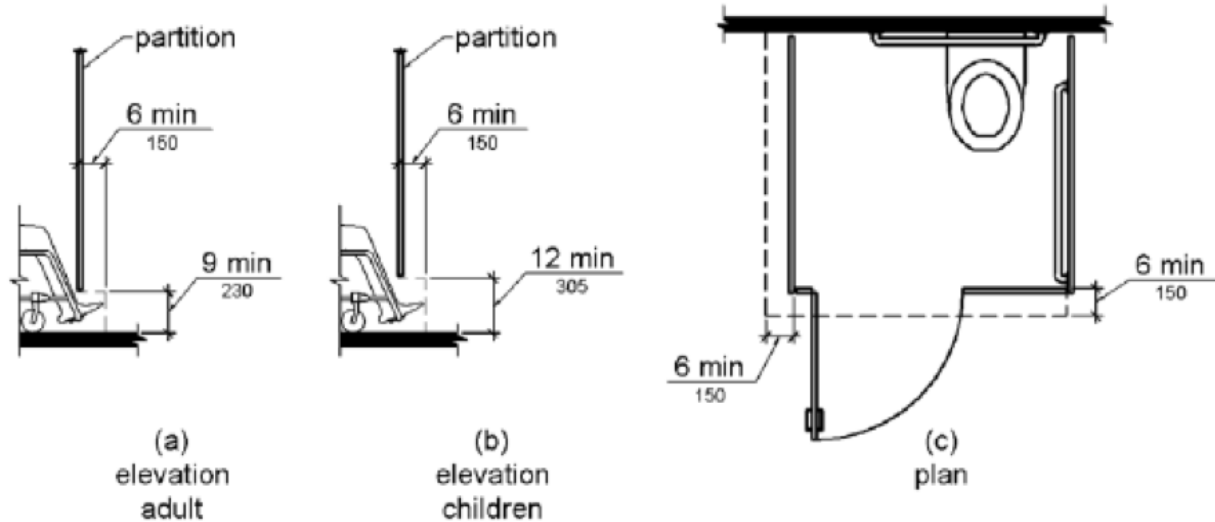

Figure 604.8.1.4 Wheelchair Accessible Toilet Compartment Toe Clearance

604.8.1.5 Grab Bars. Grab bars shall comply with 609. A side-wall grab bar complying with 604.5.1 shall be provided and shall be located on the wall closest to the water closet. In addition, a rear-wall grab bar complying with 604.5.2 shall be provided.

604.8.2 Ambulatory Accessible Compartments. Ambulatory accessible compartments shall comply with 604.8.2.

604.8.2.1 Size. Ambulatory accessible compartments shall have a depth of 60 inches (1525 mm) minimum and a width of 35 inches (890 mm) minimum and 37 inches (940 mm) maximum.

604.8.2.2 Doors. Toilet compartment doors, including door hardware, shall comply with 404, except that if the approach is to the latch side of the compartment door, clearance between the door side of the compartment and any obstruction shall be 42 inches (1065 mm) minimum. The door shall be self-closing. A door pull complying with 404.2.7 shall be placed on both sides of the door near the latch. Toilet compartment doors shall not swing into the minimum required compartment area.

604.8.2.3 Grab Bars. Grab bars shall comply with 609. A side-wall grab bar complying with 604.5.1 shall be provided on both sides of the compartment.

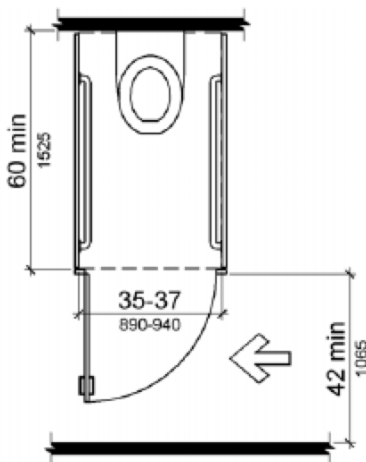

Lubrizol



MORE INSIDE™ :: VALUE BEYOND OUR PIPING SOLUTIONS



For more than 50 years, The Lubrizol Corporation has been dedicated to providing quality resources with More Inside™ – helping you work more efficiently and effectively with all Lubrizol CPVC piping systems.

ASPE-AUTHORIZED CEU COURSES: Advance your expertise and improve your Certified Plumbing Design status.

3D BIM OBJECTS: Easily and accurately specify FlowGuard Gold® and Corzan® systems, the first CPVC systems available in BIM.

For your next project, specify Lubrizol CPVC systems, approved across California (including Los Angeles city), for use in residential and commercial applications.

Learn more about all of our innovative products and services at lubrizolcpvc.com or contact Rob Zagorski at rob.zagorski@lubrizol.com or 562.857.0755.

Follow us on Twitter
at @LZ_CPVC.



FLOWGUARD GOLD
PIPE & FITTINGS

BlazeMaster
FIRE SPRINKLER SYSTEMS

CORZAN
PIPING SYSTEMS

Figure 604.8.2 Ambulatory Accessible Toilet Compartment

604.8.3 Coat Hooks and Shelves. Coat hooks shall be located within one of the reach ranges specified in 308. Shelves shall be located 40 inches (1015 mm) minimum and 48 inches (1220 mm) maximum above the finish floor.

604.9 Water Closets and Toilet Compartments for Children's Use. Water closets and toilet compartments for children's use shall comply with 604.9.

Advisory 604.9 Water Closets and Toilet Compartments for Children's Use. The requirements in 604.9 are to be followed where the exception for children's water closets in 604.1 is used. The following table provides additional guidance in applying the specifications for water closets for children according to the age group served and reflects the differences in the size, stature, and reach ranges of children ages 3 through 12. The specifications chosen should correspond to the age of the primary user group. The specifications of one age group should be applied consistently in the installation of a water closet and related elements.

	Ages 3 and 4	Ages 5 through 8	Ages 9 through 12
Water Closet Centerline	12 inches (305 mm)	12 to 15 inches (305 to 380 mm)	15 to 18 inches (380 to 455 mm)
Toilet Seat Height	11 to 12 inches (280 to 305 mm)	12 to 15 inches (305 to 380 mm)	15 to 17 inches (380 to 430 mm)
Grab Bar Height	18 to 20 inches (455 to 510 mm)	20 to 25 inches (510 to 635 mm)	25 to 27 inches (635 to 685 mm)
Dispenser Height	14 inches (355 mm)	14 to 17 inches (355 to 430 mm)	17 to 19 inches (430 to 485 mm)

Advisory Specifications for Water Closets Serving Children Ages 3 through 12

604.9.1 Location. The water closet shall be located with a wall or partition to the rear and to one side. The centerline of the water closet shall be 12 inches (305 mm) minimum and 18 inches (455 mm) maximum from the side wall or partition, except that the water closet shall be 17 inches (430 mm) minimum and 19 inches (485 mm) maximum from the side wall or partition in the ambulatory accessible toilet compartment specified in 604.8.2. Compartments shall be arranged for left-hand or right-hand approach to the water closet.

604.9.2 Clearance. Clearance around a water closet shall comply with 604.3.

604.9.3 Height. The height of water closets shall be 11 inches (280 mm) minimum and 17 inches (430 mm) maximum measured to the top of the seat. Seats shall not be sprung to return to a lifted position.

604.9.4 Grab Bars. Grab bars for water closets shall comply with 604.5.

604.9.5 Flush Controls. Flush controls shall be hand operated or automatic. Hand operated flush controls shall comply with 309.2 and 309.4 and shall be installed 36 inches (915 mm) maximum above the finish floor. Flush controls shall be located on the open side of the water closet except in ambulatory accessible compartments complying with 604.8.2.

604.9.6 Dispensers. Toilet paper dispensers shall comply with 309.4 and shall be 7 inches (180 mm) minimum and 9 inches (230 mm) maximum in front of the water closet measured to the centerline of the dispenser. The outlet of the dispenser shall be 14 inches (355 mm) minimum and 19 inches (485 mm) maximum above the finish floor. There shall be a clearance of 1½ inches (38 mm) minimum below the grab bar. Dispensers shall not be of a type that controls delivery or that does not allow continuous paper flow.

604.9.7 Toilet Compartments. Toilet compartments shall comply with 604.8.

605 Urinals

605.1 General. Urinals shall comply with 605.

Advisory 605.1 General. Stall-type urinals provide greater accessibility for a broader range of persons, including people of short stature.

605.2 Height and Depth. Urinals shall be the stall-type or the wall-hung type with the rim 17 inches (430 mm) maximum above the finish floor or ground. Urinals shall be 13½ inches (345 mm) deep minimum measured from the outer face of the urinal rim to the back of the fixture.

XERXES® GREASE INTERCEPTORS

IAPMO models to 30,000 gallons
30 Year Warranty



2029 Verdugo Blvd., #236
Montrose, CA 91020
tel: 888.959.2937

www.enviroproductswest.com



P2S Engineering is proud
to support ASPE-OC

JOIN OUR TEAM!

We are currently hiring engineers in our Long Beach and San Diego offices. For more information please visit our website at p2seng.com

MECHANICAL | ELECTRICAL | PLUMBING
TECHNOLOGY | COMMISSIONING | ENERGY

5000 East Spring Street, 8th Floor
Long Beach, CA 90815

www.p2seng.com



YEARS OF EXCELLENCE



2029 Verdugo Blvd. #236
Montrose, CA 91020

John Deunay, CPD

john@enviroproductswest.com

o. 888.959.2937 x302
c. 818.687.6911
f. 888.959.2973

ENVIROPRODUCTSWEST.COM

DELCO  SALES

Chris Nicosia, CPMR
CEO

5375 E. Hunter Avenue • Anaheim, CA 92807
Phone: 714-888-2444 • Fax: 714-888-2448
Cell: 714-273-5413 • cnicosia@delcosales.com
www.delcosales.com

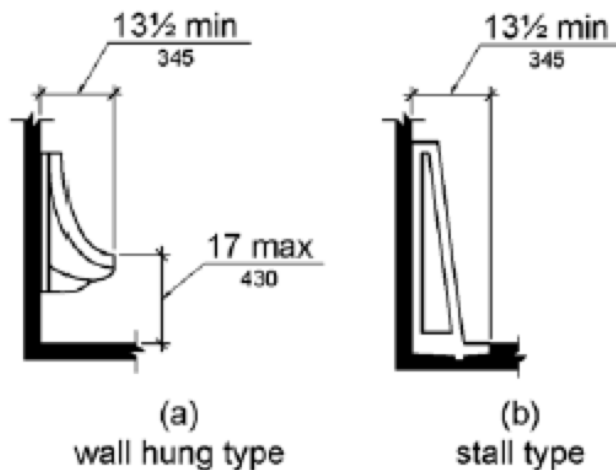

Figure 605.2 Height and Depth of Urinals

605.3 Clear Floor Space. A clear floor or ground space complying with 305 positioned for forward approach shall be provided.

605.4 Flush Controls. Flush controls shall be hand operated or automatic. Hand operated flush controls shall comply with 309.

606 Lavatories and Sinks

606.1 General. Lavatories and sinks shall comply with 606.

Advisory 606.1 General. If soap and towel dispensers are provided, they must be located within the reach ranges specified in 308. Locate soap and towel dispensers so that they are conveniently usable by a person at the accessible lavatory.

606.2 Clear Floor Space. A clear floor space complying with 305, positioned for a forward approach, and knee and toe clearance complying with 306 shall be provided.

EXCEPTIONS: 1. A parallel approach complying with 305 shall be permitted to a kitchen sink in a space where a cook top or conventional range is not provided and to wet bars.

2. A lavatory in a toilet room or bathing facility for a single occupant accessed only through a private office and not for common use or public use shall not be required to provide knee and toe clearance complying with 306.

3. In residential dwelling units, cabinetry shall be permitted under lavatories and kitchen sinks provided that all of the following conditions are met:

1. the cabinetry can be removed without removal or replacement of the fixture;
2. the finish floor extends under the cabinetry; and
3. the walls behind and surrounding the cabinetry are finished.

4. A knee clearance of 24 inches (610 mm) minimum above the finish floor or ground shall be permitted at lavatories and sinks used primarily by children 6 through 12 years where the rim or counter surface is 31 inches (785 mm) maximum above the finish floor or ground.

5. A parallel approach complying with 305 shall be permitted to lavatories and sinks used primarily by children 5 years and younger.

6. The dip of the overflow shall not be considered in determining knee and toe clearances.

7. No more than one bowl of a multi-bowl sink shall be required to provide knee and toe clearance complying with 306.

606.3 Height. Lavatories and sinks shall be installed with the front of the higher of the rim or counter surface 34 inches (865 mm) maximum above the finish floor or ground.

EXCEPTIONS: 1. A lavatory in a toilet or bathing facility for a single occupant accessed only through a private office and not for common use or public use shall not be required to comply with 606.3.

2. In residential dwelling unit kitchens, sinks that are adjustable to variable heights, 29 inches (735 mm) minimum and 36 inches (915 mm) maximum, shall be permitted where rough-in plumbing permits connections of supply and drain pipes for sinks mounted at the height of 29 inches (735 mm).

606.4 Faucets. Controls for faucets shall comply with 309. Hand-operated metering faucets shall remain open for 10 seconds minimum.



Anne Yardley Caldwell

ayardley@elmcoduddy.com



Stainless Steel & Terrazzo
Plumbing Fixtures



Thermostatic Mixing Valves



Eyewashes, Eye/Face Washes
& Emergency Drench Showers



Vacuum Plumbing Systems for
Correctional, Commercial
Applications, Water Conservation
and Infection Prevention



Polypropylene (PP-R) Pipe for use in
pressurized plumbing and mechanical
systems of all sizes



Cast Iron, PVC, ABS, & CPVC Pipe &
Fittings for Plumbing
& Industrial Systems



Tankless/Instantaneous
Electric Water Heaters



Access Panels & Lead Roof Flashings,
Roof Access Hatches



Drainage Products & Trench Drains
& Oil/Water Separators



Low NOx Water Heaters & Boilers,
Hot Water Storage Tanks
& Solar Thermal Equipment



Bronze, Brass & Cast Iron, Gates,
Globes & Checks, Ball Valves, Cast
Iron Butterfly Valves & High Perform-
ance Butterfly Valves



Couplings: No-Hub, No-Hub Heavy
Weight, Specialty, Flex-Seal, End Caps



Water Cooler, Traditional &
Contemporary Outdoor Drinking
Fountains, Bottle Fillers, Hydrants
& Hydration Station for
indoor/outdoor Application



Fire Protection Products:
Fire Extinguishers,
Hose & Valve Cabinets



Trap Primers, Water Hammer
Arrestors & Accessories



Packaged Pumping Systems



A KOHLER COMPANY

Digital Thermostatic Faucets &
Showers.



Sump, Effluent & Sewage Controls,
Engineered Customer Controls,
Embedded Controls, Ceramic
Filtration Solutions



Thermometers, Pressure Gauges
& Instruments



Stainless Steel Surgical Scrub Sinks,
Hospital, Patient Care Systems &
Behavioral Healthcare Products

606.5 Exposed Pipes and Surfaces. Water supply and drain pipes under lavatories and sinks shall be insulated or otherwise configured to protect against contact. There shall be no sharp or abrasive surfaces under lavatories and sinks.

607 Bathtubs

607.1 General. Bathtubs shall comply with 607.

607.2 Clearance. Clearance in front of bathtubs shall extend the length of the bathtub and shall be 30 inches (760 mm) wide minimum. A lavatory complying with 606 shall be permitted at the control end of the clearance. Where a permanent seat is provided at the head end of the bathtub, the clearance shall extend 12 inches (305 mm) minimum beyond the wall at the head end of the bathtub.

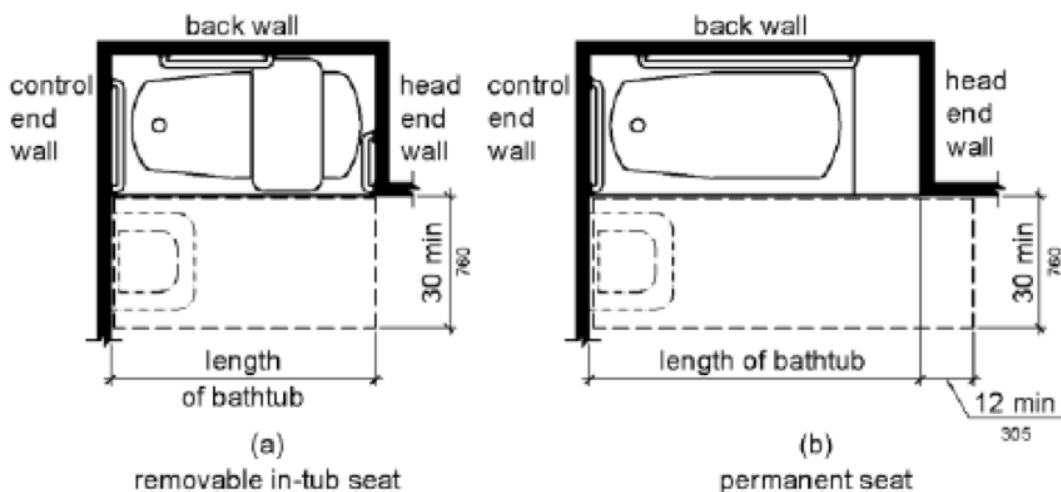

Figure 607.2 Clearance for Bathtubs

607.3 Seat. A permanent seat at the head end of the bathtub or a removable in-tub seat shall be provided. Seats shall comply with 610.

607.4 Grab Bars. Grab bars for bathtubs shall comply with 609 and shall be provided in accordance with 607.4.1 or 607.4.2.

EXCEPTIONS: 1. Grab bars shall not be required to be installed in a bathtub located in a bathing facility for a single occupant accessed only through a private office and not for common use or public use provided that reinforcement has been installed in walls and located so as to permit the installation of grab bars complying with 607.4.

2. In residential dwelling units, grab bars shall not be required to be installed in bathtubs located in bathing facilities provided that reinforcement has been installed in walls and located so as to permit the installation of grab bars complying with 607.4.

607.4.1 Bathtubs With Permanent Seats. For bathtubs with permanent seats, grab bars shall be provided in accordance with 607.4.1.

607.4.1.1 Back Wall. Two grab bars shall be installed on the back wall, one located in accordance with 609.4 and the other located 8 inches (205 mm) minimum and 10 inches (255 mm) maximum above the rim of the bathtub. Each grab bar shall be installed 15 inches (380 mm) maximum from the head end wall and 12 inches (305 mm) maximum from the control end wall.

607.4.1.2 Control End Wall. A grab bar 24 inches (610 mm) long minimum shall be installed on the control end wall at the front edge of the bathtub.

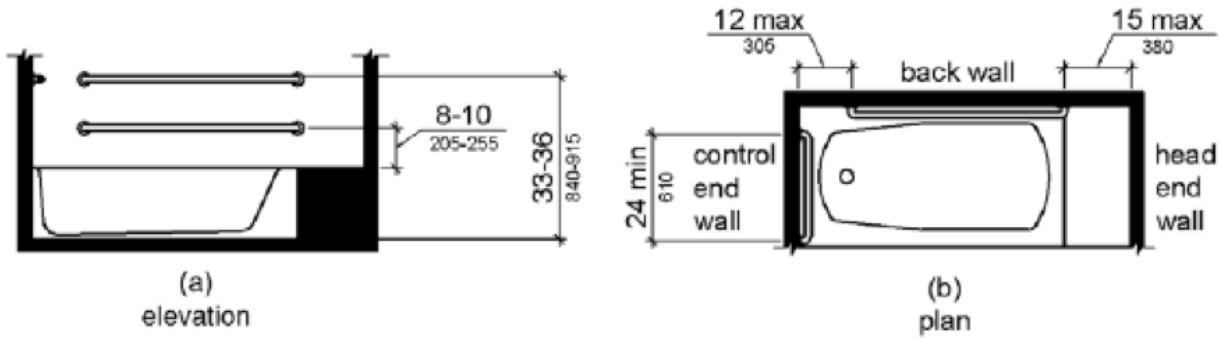

Figure 607.4.1 Grab Bars for Bathtubs with Permanent Seats

607.4.2 Bathtubs Without Permanent Seats. For bathtubs without permanent seats, grab bars shall comply with 607.4.2.

607.4.2.1 Back Wall. Two grab bars shall be installed on the back wall, one located in accordance with 609.4 and other located 8 inches (205 mm) minimum and 10 inches (255 mm) maximum above the rim of the bathtub. Each grab bar shall be 24 inches (610 mm) long minimum and shall be installed 24 inches (610 mm) maximum from the head end wall and 12 inches (305 mm) maximum from the control end wall.

607.4.2.2 Control End Wall. A grab bar 24 inches (610 mm) long minimum shall be installed on the control end wall at the front edge of the bathtub.

607.4.2.3 Head End Wall. A grab bar 12 inches (305 mm) long minimum shall be installed on the head end wall at the front edge of the bathtub.

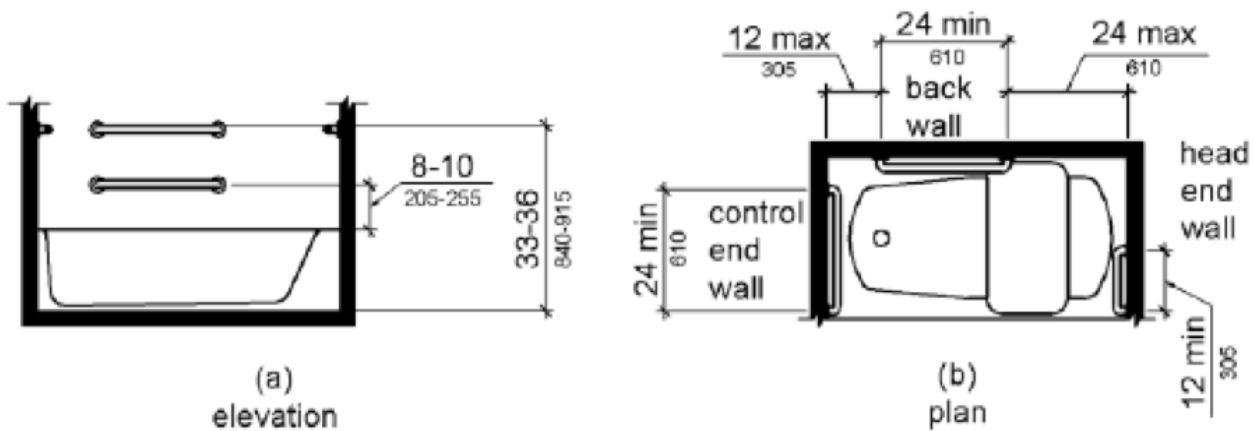

Figure 607.4.2 Grab Bars for Bathtubs with Removable In-Tub Seats

607.5 Controls. Controls, other than drain stoppers, shall be located on an end wall. Controls shall be between the bathtub rim and grab bar, and between the open side of the bathtub and the centerline of the width of the bathtub. Controls shall comply with 309.4.

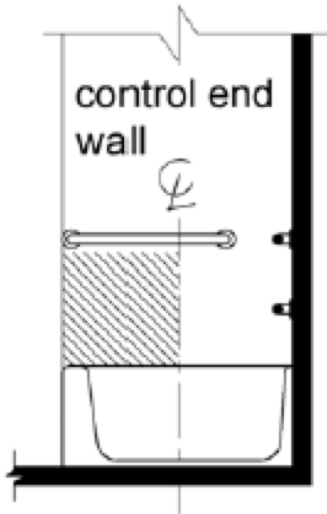

Figure 607.5 Bathtub Control Location

607.6 Shower Spray Unit and Water. A shower spray unit with a hose 59 inches (1500 mm) long minimum that can be used both as a fixed-position shower head and as a hand-held shower shall be provided. The shower spray unit shall have an on/off control with a non-positive shut-off. If an adjustable-height shower head on a vertical bar is used, the bar shall be installed so as not to obstruct the use of grab bars. Bathtub shower spray units shall deliver water that is 120°F (49°C) maximum.

Advisory 607.6 Shower Spray Unit and Water. Ensure that hand-held shower spray units are capable of delivering water pressure substantially equivalent to fixed shower heads.

607.7 Bathtub Enclosures. Enclosures for bathtubs shall not obstruct controls, faucets, shower and spray units or obstruct transfer from wheelchairs onto bathtub seats or into bathtubs. Enclosures on bathtubs shall not have tracks installed on the rim of the open face of the bathtub.

608 Shower Compartments

608.1 General. Shower compartments shall comply with 608.

Advisory 608.1 General. Shower stalls that are 60 inches (1525 mm) wide and have no curb may increase the usability of a bathroom because the shower area provides additional maneuvering space.

608.2 Size and Clearances for Shower Compartments. Shower compartments shall have sizes and clearances complying with 608.2.

608.2.1 Transfer Type Shower Compartments. Transfer type shower compartments shall be 36 inches (915 mm) by 36 inches (915 mm) clear inside dimensions measured at the center points of opposing sides and shall have a 36 inch (915 mm) wide minimum entry on the face of the shower compartment. Clearance of 36 inches (915 mm) wide minimum by 48 inches (1220 mm) long minimum measured from the control wall shall be provided.

Figure 608.2.1 Transfer Type Shower Compartment Size and Clearance

608.2.2 Standard Roll-In Type Shower Compartments. Standard roll-in type shower compartments shall be 30 inches (760 mm) wide minimum by 60 inches (1525 mm) deep minimum clear inside dimensions measured at center points of opposing sides and shall have a 60 inches (1525 mm) wide minimum entry on the face of the shower compartment.

608.2.2.1 Clearance. A 30 inch (760 mm) wide minimum by 60 inch (1525 mm) long minimum clearance shall be provided adjacent to the open face of the shower compartment.

EXCEPTION: A lavatory complying with 606 shall be permitted on one 30 inch (760 mm) wide minimum side of the clearance provided that it is not on the side of the clearance adjacent to the controls or, where provided, not on the side of the clearance adjacent to the shower seat.



Commissioning Agent CxA (San Marcos)

A forward-thinking, San Marcos-based company is seeking a commissioning agent (CxA) to join our team.

Axiom Commissioning Group, Inc.

Started by mechanical engineers, Axiom Commissioning Group focuses solely on commissioning projects. Axiom is looking for experienced, like-minded candidates for an immediate position who are either ACG certified or interested in becoming an ACG certified commissioning authority.

At **Axiom Commissioning Group, Inc.**, we believe our current and future success depends on hiring, developing, and retaining high caliber people. We invite you to learn more about us. Please view our website at www.axiomcx.com

Commissioning Agent CxA

Qualifications & Requirements:

- 3-5 years' experience in mechanical building design, including commissioning projects design review, commissioning specifications, startup review and all testing
- Functional Performance Testing (FPT) and Performance Verification Testing (PVT), and final commissioning report composition
- Technically proficient in HVAC systems design, DDC control systems and lighting control systems
- EIT or PE certification helpful but not required
- Certification with ACG as a Commissioning Authority for military, commercial, and hospitality projects helpful but not required
- Excellent written and verbal communications and some travel (mostly in Southern California) is required.

We offer a stimulating and collaborative work environment with competitive salary & benefits and opportunities for advancement. We are proud to offer a variety of benefits including medical, dental, vision insurance, 401K match & much more.

Please send your resume, a cover letter, and your salary requirements to:

accounting@axiomcx.com



Ranked as one of the top engineering companies in San Diego by the San Diego Business Journal, T-Squared Professional Engineers, Inc. is a 24 year-old, privately held, industry-leading consulting engineering firm specializing in HVAC, Electrical, and Plumbing Systems Design as well as Photo-Voltaic Systems Design.

At **T-Squared Professional Engineers**, we believe our current and future success depends on hiring, developing, and retaining high caliber people. We are always interested in hearing from exceptional candidates, and we invite you to learn more about us. Please view our website at www.tsqeng.com.

Mechanical Designer/Engineer (Carlsbad/Vista)

Overview:

Immediate opening for a Mechanical Designer/Engineer to join our team.

The successful candidate will be professional, self-motivated, energetic, & enthusiastic with excellent communication and inter-personal skills, and a desire to contribute to our continued success. Previous consulting engineering firm experience required.

We value your experience including the following qualifications, technical skills, and abilities:

- Strong technical skills and the ability to produce accurate and timely HVAC systems designs for commercial, educational, health-care and military facilities
- Design and documentation skills
- The ability to develop layouts and detailed schematics for HVAC systems
- Expertise in piping and hydronic designs
- Comprehensive understanding of energy conservation reports
- Title - 24 calculation
- LEED design experience with a focus on energy efficiency and sustainability
- LEED documentation and coordination skills

Qualifications / Requirements:

- Bachelor's degree in Mechanical Engineering (or related industry experience) and a minimum of 4 years' experience in Mechanical design, or equivalent combination of education and experience
- Recent relevant experience in the engineering/construction field
- Experience in packaged equipment and central plants
- Knowledge of CA Energy Standards - Code Requirements
- EIT or PE certificates helpful but not required.
- LEED – AP preferred
- Team-player: Demonstrated ability to effectively manage a projects and/or take direction from project managers
- Proficiency with MS Office and CAD
- Strong verbal and writing communication skills

Plumbing Designer/Engineer (Carlsbad/Vista)

Overview:

Immediate opening for a Plumbing Designer to join our team.

The successful candidate will be professional, self-motivated, energetic & enthusiastic with excellent communication and inter-personal skills and a desire to contribute to our continued success. Previous consulting engineering firm experience required.

We Value Your Experience Including the Following Qualifications, Technical Skills & Abilities:

Design and assist with designing Plumbing Systems for commercial, educational, health-care and military facilities.

- Prepare detailed layouts for all drainage and water supply systems for all types of facilities, piping & hydronic designs
- Research & select equipment from various manufacturers
- Complete fixtures / equipment schedules
- Perform calculations for a project, such as equipment selection and sizing, fixtures calculations, product specifications, and design and layout for roof drains, sanitary lines, and water lines.
- Estimate construction costs and evaluate feasibility of construction
- Comprehensive understanding of Code Compliance
- Provide drafting support using AutoCAD and BIM to drafting staff

Qualifications & Requirements:

- A minimum 4 years of directly related experience in plumbing design or equivalent combination of education and experience.
- Recent relevant experience in the engineering/construction field
- Plumbing design from Schematic Design through Construction Administration
- Comprehensive knowledge of plumbing engineering fundamentals
- LEED – AP preferred
- Team-player: Demonstrated ability to effectively manage a projects and/or take direction from project managers
- Proficiency with MS Office and AutoCAD
- Strong verbal and writing communication skills

Be part of our team and design your success. We offer a stimulating and collaborative work environment with competitive salary & benefits and opportunities for advancement. We are proud to offer a variety of benefits including medical, dental, vision insurance, 401K match & much more.

Please send your resume, a cover letter, and your salary requirements to

jobs@tsqeng.com

Please be sure to include the following in your cover letter:

- 1.) Why you are interested in this position,
- 2.) The special talents or strengths you will bring to our team and
- 3.) An example of a success that demonstrates your skills and abilities, for you are particularly proud.

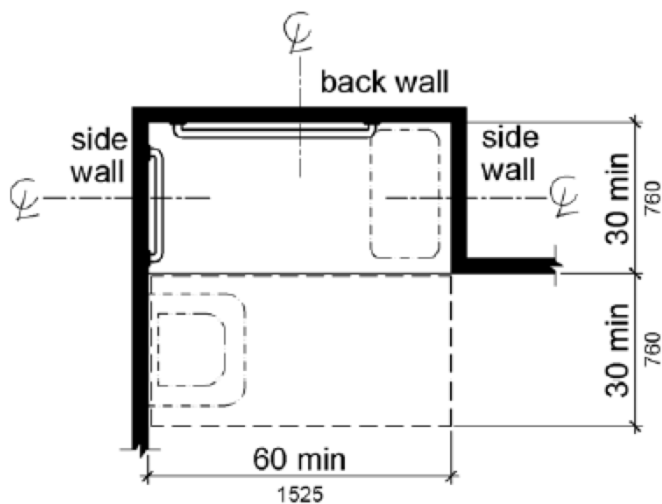

Note: inside finished dimensions measured at the center points of opposing sides

Figure 608.2.2 Standard Roll-In Type Shower Compartment Size and Clearance

608.2.3 Alternate Roll-In Type Shower Compartments. Alternate roll-in type shower compartments shall be 36 inches (915 mm) wide and 60 inches (1525 mm) deep minimum clear inside dimensions measured at center points of opposing sides. A 36 inch (915 mm) wide minimum entry shall be provided at one end of the long side of the compartment.

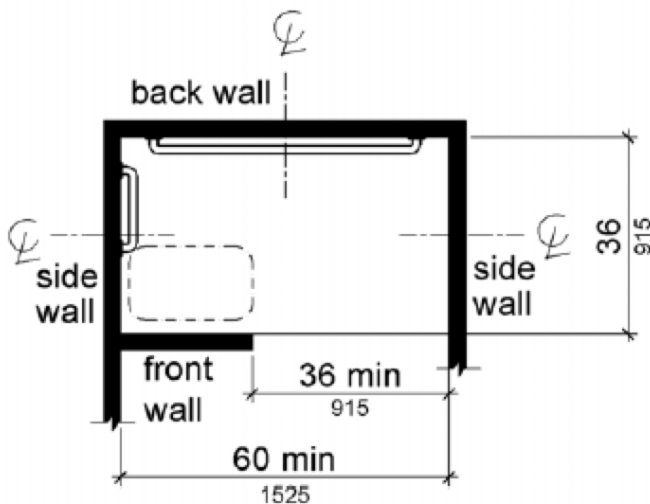

Note: inside finished dimensions measured at the center points of opposing sides

Figure 608.2.3 Alternate Roll-In Type Shower Compartment Size and Clearance

608.3 Grab Bars. Grab bars shall comply with 609 and shall be provided in accordance with 608.3. Where multiple grab bars are used, required horizontal grab bars shall be installed at the same height above the finish floor.

EXCEPTIONS: 1. Grab bars shall not be required to be installed in a shower located in a bathing facility for a single occupant accessed only through a private office, and not for common use or public use provided that reinforcement has been installed in walls and located so as to permit the installation of grab bars complying with 608.3.

2. In residential dwelling units, grab bars shall not be required to be installed in showers located in bathing facilities provided that reinforcement has been installed in walls and located so as to permit the installation of grab bars complying with 608.3.

608.3.1 Transfer Type Shower Compartments. In transfer type compartments, grab bars shall be provided across the control wall and back wall to a point 18 inches (455 mm) from the control wall.



Alex Jimenez
 Cell: (909) 203-2008
 Office: (714) 888-2444
AJimenez@Delcosales.com
www.Delcosales.com

5375 E Hunter Avenue Anaheim, CA 92807



AB & I Foundry
 Cast iron pipe, fittings and no-hub couplings.
www.abifoundry.com



Anaco Couplings
 All stainless no-hub couplings.
www.anaco-husky.com



Commercial & Residential water heaters both gas & electric.
www.hotwater.com



Commercial & Residential water heaters both gas & electric.
www.americanwaterheater.com



Bemis / Church
 Plastic, wood and soft seats for residential, Commercial and specialty applications
www.toiletseats.com



Brae
 Rainwater harvesting. Complete systems designed to conserve water and help meet your sustainability objectives.
www.braewater.com



Eemax
 Instantaneous, tank-less, electric water heaters
www.eemaxinc.com



Fox Environmental
 Fox washdown units. Designed to divert all your Wash down water to waste while allowing rainwater to go to storm water.
www.foxenviro.com/au



Holdrite
 The market leader in pipe support and alignment systems featuring Holdrite, Lockrite, Pexrite Quick strap, and HydroFlame
www.holdrite.com



Just Manufacturing
 Stainless steel sinks for Commercial, residential and institutional applications
www.justmfg.com



Liberty Pumps
 Sump, drain, effluent, sewage and grinder pumps and pump systems.
www.libertypumps.com



Metcraft Industries
 Stainless Steel Plumbing Products for Correctional Market, Hospitals Schools
www.metcraftindustries.com



Washing Machine & Ice Maker boxes, Dearborn tubular, ADA Trap Covers
www.oatey.com



Commercial & Residential water heaters both gas & electric.
www.statewaterheaters.com



Tankless Commercial & Residential water heaters
www.takagi.com



Orion
 No hub fittings for acid waste drainage systems. Rionfuse polypropylene fittings, neutralization tanks, corrosion resistant lab sinks.
www.orionfittings.com



Powers
 Water tempering and process control specialists
www.powerscontrols.com



Sloan Valve
 Manual and sensor operated flushometers, Faucets and vitreous china fixtures, hand dryers, SloanStone systems
www.sloanvalve.com



Watts Drainage / Blücher
 Specification drains, floor sinks, interceptors, trench drains, carriers stainless steel drainage systems, floor drains, shower drains.
www.watts.com/drainage
www.blucherdrains.com



Watts Water Technologies
 A complete line of water safety, and backflow prevention products. Regulators, automatic control valves, gate globe and check valves.
www.watts.com

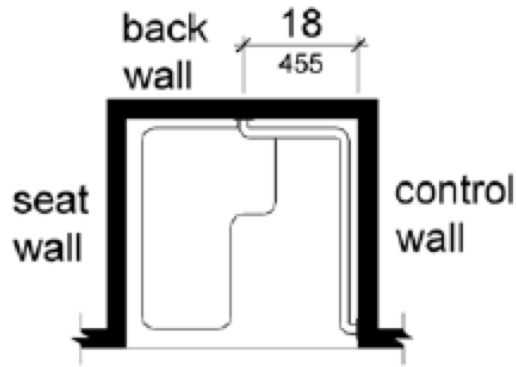

Figure 608.3.1 Grab Bars for Transfer Type Showers

608.3.2 Standard Roll-In Type Shower Compartments. Where a seat is provided in standard roll-in type shower compartments, grab bars shall be provided on the back wall and the side wall opposite the seat. Grab bars shall not be provided above the seat. Where a seat is not provided in standard roll-in type shower compartments, grab bars shall be provided on three walls. Grab bars shall be installed 6 inches (150 mm) maximum from adjacent walls.

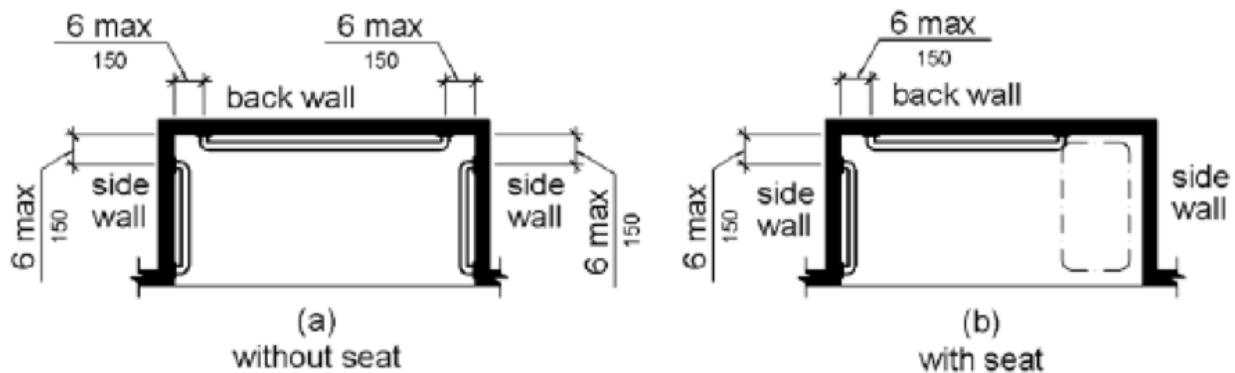

Figure 608.3.2 Grab Bars for Standard Roll-In Type Showers

608.3.3 Alternate Roll-In Type Shower Compartments. In alternate roll-in type shower compartments, grab bars shall be provided on the back wall and the side wall farthest from the compartment entry. Grab bars shall not be provided above the seat. Grab bars shall be installed 6 inches (150 mm) maximum from adjacent walls.

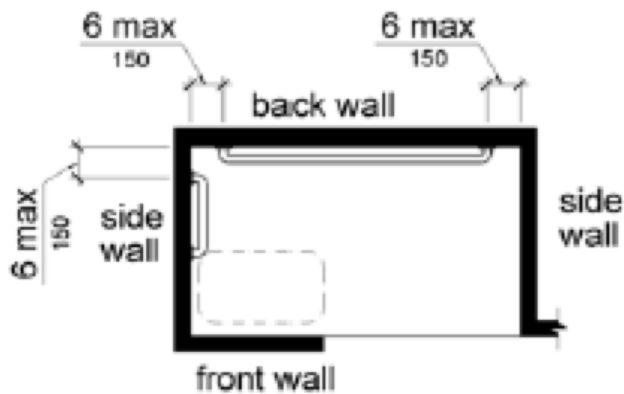

Figure 608.3.3 Grab Bars for Alternate Roll-In Type Showers

608.4 Seats. A folding or non-folding seat shall be provided in transfer type shower compartments. A folding seat shall be provided in roll-in type showers required in transient lodging guest rooms with mobility features complying with 806.2. Seats shall comply

with 610.

EXCEPTION: In residential dwelling units, seats shall not be required in transfer type shower compartments provided that reinforcement has been installed in walls so as to permit the installation of seats complying with 608.4.

608.5 Controls. Controls, faucets, and shower spray units shall comply with 309.4.

608.5.1 Transfer Type Shower Compartments. In transfer type shower compartments, the controls, faucets, and shower spray unit shall be installed on the side wall opposite the seat 38 inches (965 mm) minimum and 48 inches (1220 mm) maximum above the shower floor and shall be located on the control wall 15 inches (380 mm) maximum from the centerline of the seat toward the shower opening.

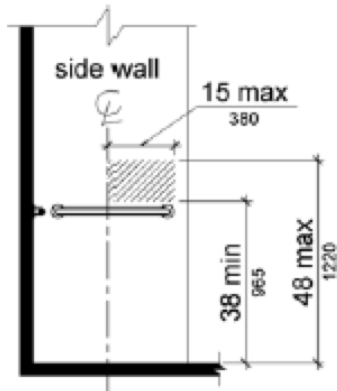

Figure 608.5.1 Transfer Type Shower Compartment Control Location

608.5.2 Standard Roll-In Type Shower Compartments. In standard roll-in type shower compartments, the controls, faucets, and shower spray unit shall be located above the grab bar, but no higher than 48 inches (1220 mm) above the shower floor. Where a seat is provided, the controls, faucets, and shower spray unit shall be installed on the back wall adjacent to the seat wall and shall be located 27 inches (685 mm) maximum from the seat wall.

Advisory 608.5.2 Standard Roll-In Type Shower Compartments. In standard roll-in type showers without seats, the shower head and operable parts can be located on any of the three walls of the shower without adversely affecting accessibility.

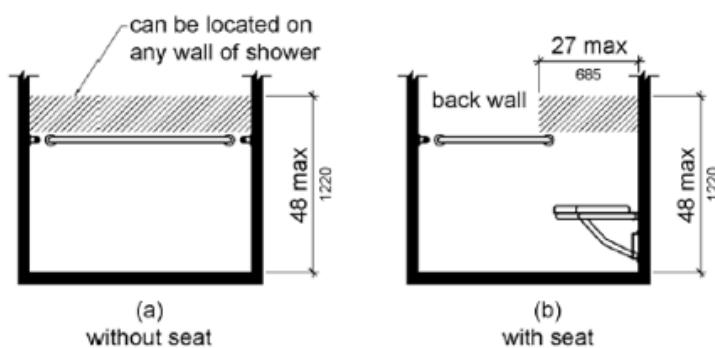

Figure 608.5.2 Standard Roll-In Type Shower Compartment Control Location

608.5.3 Alternate Roll-In Type Shower Compartments. In alternate roll-in type shower compartments, the controls, faucets, and shower spray unit shall be located above the grab bar, but no higher than 48 inches (1220 mm) above the shower floor. Where a seat is provided, the controls, faucets, and shower spray unit shall be located on the side wall adjacent to the seat 27 inches (685 mm) maximum from the side wall behind the seat or shall be located on the back wall opposite the seat 15 inches (380 mm) maximum, left or right, of the centerline of the seat. Where a seat is not provided, the controls, faucets, and shower spray unit shall be installed on the side wall farthest from the compartment entry.

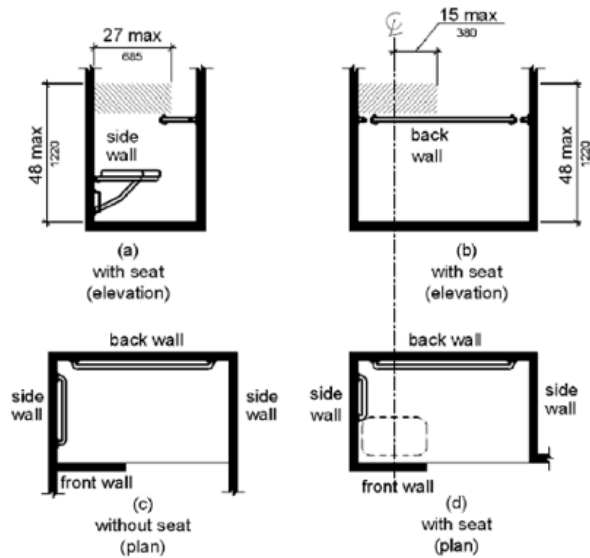

Figure 608.5.3 Alternate Roll-In Type Shower Compartment Control Location

608.6 Shower Spray Unit and Water. A shower spray unit with a hose 59 inches (1500 mm) long minimum that can be used both as a fixed-position shower head and as a hand-held shower shall be provided. The shower spray unit shall have an on/off control with a non-positive shut-off. If an adjustable-height shower head on a vertical bar is used, the bar shall be installed so as not to obstruct the use of grab bars. Shower spray units shall deliver water that is 120°F (49°C) maximum.

EXCEPTION: A fixed shower head located at 48 inches (1220 mm) maximum above the shower finish floor shall be permitted instead of a hand-held spray unit in facilities that are not medical care facilities, long-term care facilities, transient lodging guest rooms, or residential dwelling units.

Advisory 608.6 Shower Spray Unit and Water. Ensure that hand-held shower spray units are capable of delivering water pressure substantially equivalent to fixed shower heads.

608.7 Thresholds. Thresholds in roll-in type shower compartments shall be ½ inch (13 mm) high maximum in accordance with 303. In transfer type shower compartments, thresholds ½ inch (13 mm) high maximum shall be beveled, rounded, or vertical.

EXCEPTION: A threshold 2 inches (51 mm) high maximum shall be permitted in transfer type shower compartments in existing facilities where provision of a ½ inch (13 mm) high threshold would disturb the structural reinforcement of the floor slab.

608.8 Shower Enclosures. Enclosures for shower compartments shall not obstruct controls, faucets, and shower spray units or obstruct transfer from wheelchairs onto shower seats.

609 Grab Bars

609.1 General. Grab bars in toilet facilities and bathing facilities shall comply with 609.

609.2 Cross Section. Grab bars shall have a cross section complying with 609.2.1 or 609.2.2.

609.2.1 Circular Cross Section. Grab bars with circular cross sections shall have an outside diameter of 1¼ inches (32 mm) minimum and 2 inches (51 mm) maximum.

609.2.2 Non-Circular Cross Section. Grab bars with non-circular cross sections shall have a cross-section dimension of 2 inches (51 mm) maximum and a perimeter dimension of 4 inches (100 mm) minimum and 4.8 inches (120 mm) maximum.

Southern California



Christy's

Crispin
AIR RELEASE, CHECK AND BUTTERFLY VALVE
WWW.CRISPINVALVE.COM WWW.KFLOWVALVE.COM

Fernco

GreenTurtle

Guardian

IDEAL TRIDON.

LEONARD
WATER TEMPERATURE CONTROLS

MATCO-NORCA

METAL PRODUCTS COMPANY

OASIS

ROYAL
Building Products

WaterSaver

WILKINS

ZOELLER
PUMP COMPANY

ZURN
Engineered Water Solutions

ZURN PEX
PLUMBING SYSTEMS

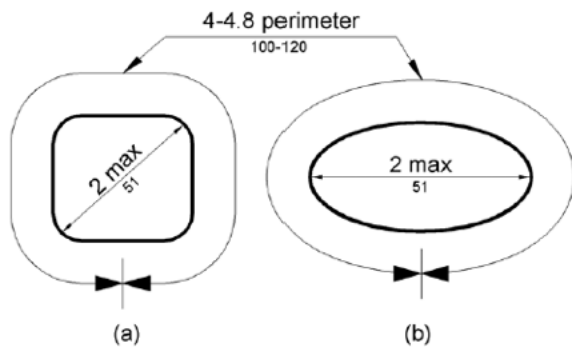

Figure 609.2.2 Grab Bar Non-Circular Cross Section

609.3 Spacing. The space between the wall and the grab bar shall be $1\frac{1}{2}$ inches (38 mm). The space between the grab bar and projecting objects below and at the ends shall be $1\frac{1}{2}$ inches (38 mm) minimum. The space between the grab bar and projecting objects above shall be 12 inches (305 mm) minimum.

EXCEPTION: The space between the grab bars and shower controls, shower fittings, and other grab bars above shall be permitted to be $1\frac{1}{2}$ inches (38 mm) minimum.

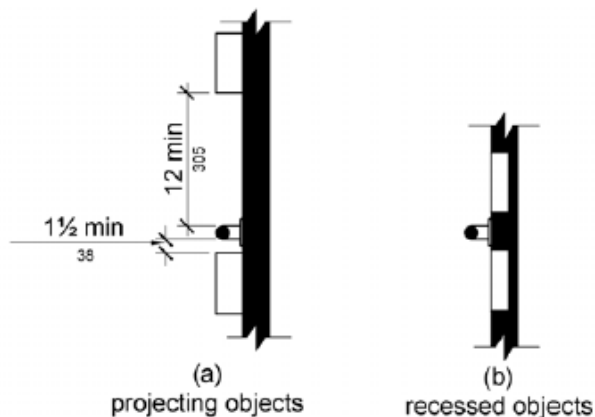

Figure 609.3 Spacing of Grab Bars

609.4 Position of Grab Bars. Grab bars shall be installed in a horizontal position, 33 inches (840 mm) minimum and 36 inches (915 mm) maximum above the finish floor measured to the top of the gripping surface, except that at water closets for children's use complying with 604.9, grab bars shall be installed in a horizontal position 18 inches (455 mm) minimum and 27 inches (685 mm) maximum above the finish floor measured to the top of the gripping surface. The height of the lower grab bar on the back wall of a bathtub shall comply with 607.4.1.1 or 607.4.2.1.

609.5 Surface Hazards. Grab bars and any wall or other surfaces adjacent to grab bars shall be free of sharp or abrasive elements and shall have rounded edges.

609.6 Fittings. Grab bars shall not rotate within their fittings.

609.7 Installation. Grab bars shall be installed in any manner that provides a gripping surface at the specified locations and that does not obstruct the required clear floor space.

609.8 Structural Strength. Allowable stresses shall not be exceeded for materials used when a vertical or horizontal force of 250 pounds (1112 N) is applied at any point on the grab bar, fastener, mounting device, or supporting structure.

610 Seats

610.1 General. Seats in bathtubs and shower compartments shall comply with 610.

610.2 Bathtub Seats. The top of bathtub seats shall be 17 inches (430 mm) minimum and 19 inches (485 mm) maximum above the bathroom finish floor. The depth of a removable in-tub seat shall be 15 inches (380 mm) minimum and 16 inches (405 mm) maxi-

mm. The seat shall be capable of secure placement. Permanent seats at the head end of the bathtub shall be 15 inches (380 mm) deep minimum and shall extend from the back wall to or beyond the outer edge of the bathtub.

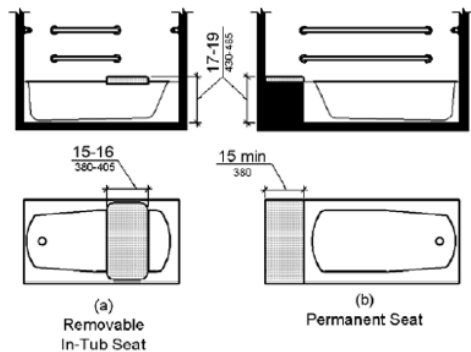

Figure 610.2 Bathtub Seats

610.3 Shower Compartment Seats. Where a seat is provided in a standard roll-in shower compartment, it shall be a folding type, shall be installed on the side wall adjacent to the controls, and shall extend from the back wall to a point within 3 inches (75 mm) of the compartment entry. Where a seat is provided in an alternate roll-in type shower compartment, it shall be a folding type, shall be installed on the front wall opposite the back wall, and shall extend from the adjacent side wall to a point within 3 inches (75 mm) of the compartment entry. In transfer-type showers, the seat shall extend from the back wall to a point within 3 inches (75 mm) of the compartment entry. The top of the seat shall be 17 inches (430 mm) minimum and 19 inches (485 mm) maximum above the bathroom finish floor. Seats shall comply with 610.3.1 or 610.3.2.

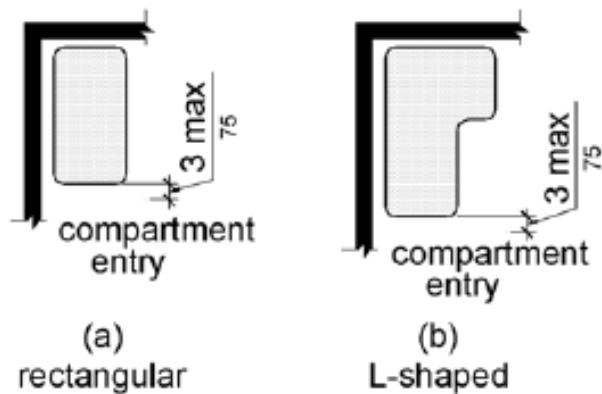

Figure 610.3 Extent of Seat

610.3.1 Rectangular Seats. The rear edge of a rectangular seat shall be 2½ inches (64 mm) maximum and the front edge 15 inches (380 mm) minimum and 16 inches (405 mm) maximum from the seat wall. The side edge of the seat shall be 1½ inches (38 mm) maximum from the adjacent wall.

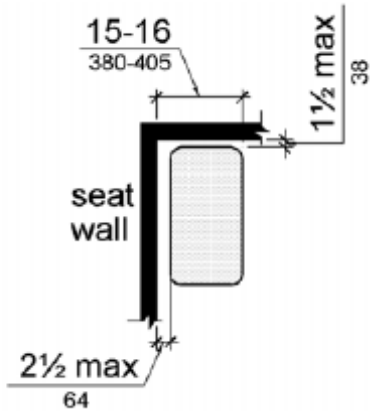

Figure 610.3.1 Rectangular Shower Seat

610.3.2 L-Shaped Seats. The rear edge of an L-shaped seat shall be 2½ inches (64 mm) maximum and the front edge 15 inches (380 mm) minimum and 16 inches (405 mm) maximum from the seat wall. The rear edge of the “L” portion of the seat shall be 1½ inches (38 mm) maximum from the wall and the front edge shall be 14 inches (355 mm) minimum and 15 inches (380 mm) maximum from the wall. The end of the “L” shall be 22 inches (560 mm) minimum and 23 inches maximum (585 mm) from the main seat wall.

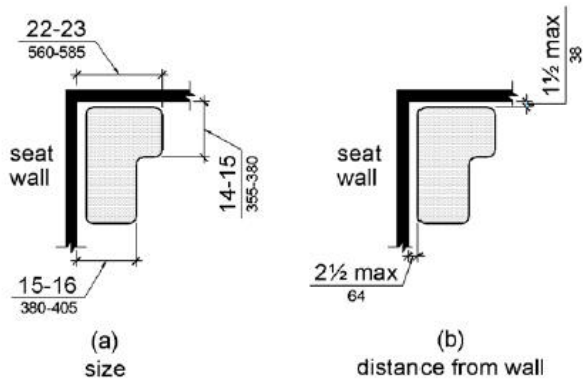

Figure 610.3.2 L-Shaped Shower Seat

610.4 Structural Strength. Allowable stresses shall not be exceeded for materials used when a vertical or horizontal force of 250 pounds (1112 N) is applied at any point on the seat, fastener, mounting device, or supporting structure.

611 Washing Machines and Clothes Dryers

611.1 General. Washing machines and clothes dryers shall comply with 611.

611.2 Clear Floor Space. A clear floor or ground space complying with 305 positioned for parallel approach shall be provided. The clear floor or ground space shall be centered on the appliance.

611.3 Operable Parts. Operable parts, including doors, lint screens, and detergent and bleach compartments shall comply with 309.

611.4 Height. Top loading machines shall have the door to the laundry compartment located 36 inches (915 mm) maximum above the finish floor. Front loading machines shall have the bottom of the opening to the laundry compartment located 15 inches (380 mm) minimum and 36 inches (915 mm) maximum above the finish floor.

REPRESENTING:





weil aquatronics

Treating Water as a Resource™

	<ul style="list-style-type: none"> ✦ Submersible, vertical, and dry pit sewage and sump pumps ✦ Condensate return, boiler feed, and circulating pumps ✦ Submersible and vertical grinder pumps, "Slicer" pumps, "Mover" pumps, "Scum Blaster" systems, prefabricated lift stations
---	---

	<ul style="list-style-type: none"> ✦ Submersible and dry pit non-clog sewage, effluent and wastewater pumps ✦ Grinder pumps, cutter pumps, jacketed pumps, and portable dewatering pumps ✦ High temperature and corrosion resistant pumps ✦ 10 GPM to over 10,000 GPM, 1/2 HP to over 500 HP Prefabricated lift stations
---	--

	<ul style="list-style-type: none"> ✦ UL- and ETL-listed packaged variable and constant speed pumping systems ✦ Domestic water, HVAC, irrigation, and fire pump packages ✦ Custom engineering and design capabilities ✦ Each system full factory-tested and warranted
---	--

	<ul style="list-style-type: none"> ✦ High performance self-priming and end suction centrifugal pumps ✦ Standard heavy-wall ductile iron volutes and 17-4 PH stainless steel shafts ✦ Shimless impeller adjustment and cartridge-type SC/TC mechanical seals
---	--

	<ul style="list-style-type: none"> ✦ Non-chemical water treatment using ozone technologies ✦ For cooling towers, lakes, fountains, aquariums, swimming pools and other open systems ✦ AquaPak™ EWS emergency water supply packages for critical facilities ✦ CleanStream™ cooling tower filtration packages
--	---

	<ul style="list-style-type: none"> ✦ Packaged fire pump systems ✦ Inline, end suction and double suction circulating pumps ✦ Turbine, axial, and mixed flow pumps ✦ Vertical and horizontal multi-stage pumps
---	---

	<ul style="list-style-type: none"> ✦ PURAIN Self-Cleaning Pre-Filters for Rainwater Collection Systems ✦ AQUALOOP Graywater Treatment <ul style="list-style-type: none"> • 6 Log Reduction of Bacteria (99.9999%) and 99.7% Virus Removal • NSF 350 Certification (Pending) ✦ DRAINMAX Tunnel Infiltration Products for On-Site Detention
---	---

	<ul style="list-style-type: none"> ✦ Pneumatic Ejectors ✦ Diaphragm Pumps ✦ Plunger Pumps
---	--

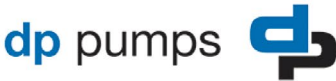
	<ul style="list-style-type: none"> ✦ Stainless steel vertical and horizontal multi-stage pumps ✦ Flows to 550 GPM, Heads to 1350 Ft., Temp to 285° F, Working Pressures to 600 PSI ✦ Cast AISI 304 or 316 stainless steel S/D casing ✦ NSF/ANSI 61 Annex G certified
---	--

	<table border="0"> <tr> <td>✦ HVAC specialties</td> <td>✦ Air separators</td> <td>✦ Butterfly valves</td> </tr> <tr> <td>✦ Triple duty valves</td> <td>✦ Flex connectors</td> <td>✦ Heat exchangers</td> </tr> <tr> <td>✦ Suction diffusers</td> <td>✦ Strainers</td> <td>✦ Flow metering devices</td> </tr> <tr> <td>✦ Expansion tanks</td> <td>✦ Hydropneumatic tanks</td> <td>✦ ASME pressure vessels</td> </tr> </table>	✦ HVAC specialties	✦ Air separators	✦ Butterfly valves	✦ Triple duty valves	✦ Flex connectors	✦ Heat exchangers	✦ Suction diffusers	✦ Strainers	✦ Flow metering devices	✦ Expansion tanks	✦ Hydropneumatic tanks	✦ ASME pressure vessels
✦ HVAC specialties	✦ Air separators	✦ Butterfly valves											
✦ Triple duty valves	✦ Flex connectors	✦ Heat exchangers											
✦ Suction diffusers	✦ Strainers	✦ Flow metering devices											
✦ Expansion tanks	✦ Hydropneumatic tanks	✦ ASME pressure vessels											

<p>ACCESSORY LINES:</p> <ul style="list-style-type: none"> ✦ Control panels, alarms ✦ Fiberglass sump basins ✦ Level sensors 	<ul style="list-style-type: none"> ✦ Custom fabricated steel covers and frames ✦ Elevator sumps, holding tanks, and alarms
--	--

SERVING THE BUILDING TRADES SINCE 1962

13630 San Antonio Drive | Norwalk, California 90650 | TEL 562.364.7430

SAN DIEGO 619-233-1716 | LAS VEGAS 702-388-7300

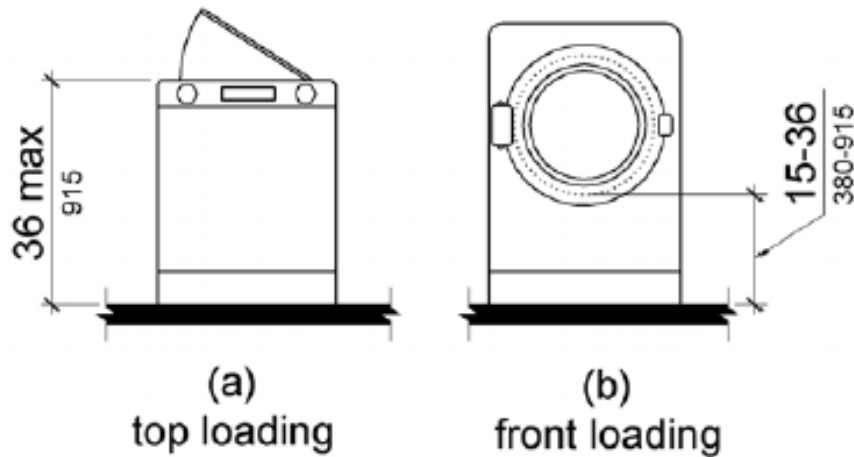

Figure 611.4 Height of Laundry Compartment Opening

612 Saunas and Steam Rooms

612.1 General. Saunas and steam rooms shall comply with 612.

612.2 Bench. Where seating is provided in saunas and steam rooms, at least one bench shall comply with 903. Doors shall not swing into the clear floor space required by 903.2.

EXCEPTION: A readily removable bench shall be permitted to obstruct the turning space required by 612.3 and the clear floor or ground space required by 903.2.

612.3 Turning Space. A turning space complying with 304 shall be provided within saunas and steam rooms.



The Moffat Group
Michael E. Moffat, President

17747 Creciente Way, Suite 8
San Diego, CA 92127-1056
858-451-2196 Office/Fax
858-245-2196 Mobile
tmg@san.rr.com
www.moffatgroup.com



Fire Pump Controllers
www.firetrol.com



2029 Verdugo Blvd. #236
Montrose, CA 91020

Linda Deunay

linda@enviroproductswest.com

o. 888.959.2937 x101
c. 818.687.6910
f. 888.959.2973

ASPE CONVENTION & EXPO

DELEGATE REPORT

October 10, 2018

The following narrative is in regards to the 2018 ASPE Convention & Expo:

Committee Meetings

1. ASPE Young Professionals Meeting

a. I decided to attend this meeting, not because I wanted to feel younger but because I wanted to see how this group has grown and progressed. I recall attending a similar meeting four years ago in Chicago. That first meeting had only a handful of younger professionals as well as a few older ones to come up with ideas of how this group can grow and shine a light on our profession. For this year's meeting, I was very happy to see a packed room of young professionals eager to share their thoughts and ideas as well as network. I hope this continues to grow nationally as well as in our local chapter.

2. Joint Region Meeting

a. The meeting was brief and somewhat informal. It mainly was to make a few announcements and make any adjustments/ edits to the proposed By-Laws that were to be discussed in detail during Sunday's Business Meeting.

Business Meetings

1. Saturday's meeting introduced the delegation to the Board of Director's and allowed all the Board Members to give their election speeches, prior to Sunday's voting session.

2. Sunday's meeting had all delegates in attendance whereby the meeting was governed by an outside parliamentarian. The decision to have him run the meeting was an excellent idea as it turned out to be an organized event that could have gone on much longer than it needed to had he not been there. The discussion of all the By-Law edits was discussed in detail and voted for the entirety of the morning session. After the lunch break, we re-assembled for the voting in of the new Board of Directors. The new National Board of Directors are:

- a. President – Carol Johnson, CPD, LEED AP, CFI, FASPE
- b. Vice President, Technical – Don Strickland, CPD, GPD, FASPE
- c. Vice President, Education – Blair Minyard, PE, CDT, CPD
- d. Vice President, Legislative – Brianne N. Hall, PE, CPD, LEED AP BD+C, GGP
- e. Vice President, Membership – Vincent (Vinny) Falkowski, PE, PMP, CCM
- f. Treasurer – Jim Zebrowski, PE, CPD, FASPE
- g. Vice President, Affiliate – Thomas P. Sharp
- h. Executive Director/CEO & Secretary – Billy Smith, FASPE
- i. Region 4 Director – Scott M. Steindler, CPD, LEED AP, ARCSA AP (IS), GPD, GGP

Exposition

The day started off with the ASPE Breakfast Award Ceremony & Keynote Address. This was a change from years past where this was normally done in the evening with a formal dinner. This was a nice change in my opinion, as it was shorter in duration and got the day started nicely. The Keynote Address was excellent, given by Derreck Kayongo, Global Soap Project Founder & former CEO of the Center for Civil and Human Rights. His speech was not only entertaining but inspirational. To see a short video about him go here:

<https://www.cnn.com/videos/world/2011/06/16/cnnheroes.kayongo.cnn>

The Exposition was great. There were many booths, so many that I couldn't go to every one during the time I spent there. The information and networking opportunities were plentiful. If you're interested in who was there here is an Exhibitor List Index:

<https://expo.aspe.org/ASPE2018/Public/Exhibitors.aspx?sortMenu=108001>

Technical Education Program

I was able to attend a few sessions. Below are the ones I attended and my thoughts.

1. Hunter's Curve Discussion Panel

a. I really enjoyed this presentation because this involves all of our projects. It has been a long time coming. The presenters provided great data that they have collected with regards to residential. They are continuing their efforts to collect data from various commercial facilities. A partnership with ASPE, IAPMO & Water Quality Association has been formed and you can view a Water Demand Calculator from IAPMO's website to see how the revised formulae works. Granted, we are still bound by the Code in how we size domestic water systems, but this is a big step in the right direction.

b. <http://www.iapmo.org/Pages/WaterDemandCalculator.aspx>

2. Hot Water Systems Design for Code Compliance

a. I had attended this same presentation four years ago in Chicago. I wanted to see how the presenter had made changes in relation to mitigating Legionella and adapting to the elimination of dead legs when possible. He referenced OSHA Technical Manual Section III, Chapter 7 Legionnaires' Disease, whereby he highlighted these two points:

i. "To minimize the growth of Legionella in the system, domestic hot water should be stored at a minimum of 60°C (140°F) and delivered at a minimum of 50° (122°F) to all outlets." He chooses to store the water at 140°F, mix and deliver at 130°F, return to the TMV and Heater at 125°F. Each handwashing and shower/tub fixture would require a point-of-use mixing valve.

ii. "Domestic hot-water recirculation pumps should run continuously. They should be excluded from energy conservation measures."

3. Advances in Plumbing Design for Healthcare

a. This was a panel discussion by a group from Acorn Mfr. Even though it was given by a group of manufacture's reps. it was wholly non-proprietary. Some highlights were how we as consultants can provide input when designing patient rooms to address concerns about ADA, Bariatric and Ligature Resistance equipment and fixtures. There is a growing need for Behavioral & Mental Healthcare and this presentation discussed facets of that.

b. There was an in-depth discussion on Legionella and how to manage it.

c. The final part defined what a Vacuum Plumbing System is and it's various benefits in a medical facility.

4. Current Trends in Medical Gas Design

a. This presentation's highlights were understanding when and where certain medical gases and support gases are used, as well as which Codes, Guidelines & Standards to reference.

b. Specific types of rooms were discussed, such as:

i. Hyperbaric Facilities

ii. Imaging

iii. Operating Rooms

1. What has changed?

a. Universal OR's

i. Larger OR to accommodate different types of procedures

b. Hybrid OR's

i. Robotics

c. More booms

d. Prefabricated Ceiling Systems/Stick Built Ceilings

c. General Prefabrication and use of various Booms

Sincerely,

tk1sc

Andrew Cole

Associate - Plumbing



1681 W. SECOND ST.
POMONA, CA 91766-1252

ERIC DECKER TEL. 626-797-9710
BUSINESS CELL. 909-762-0924
DEVELOPMENT FAX. 626-798-4659
GROUP EMAIL: EDECKER@DAWSONCO.COM

7044 CONVOY COURT
SAN DIEGO, CA 92111-1017



Bell & Gossett
a xylem brand

CENTRIFUGAL PUMPS, VARIABLE SPEED PUMPING SYSTEMS, VERTICAL TURBINE PUMPS, CIRCULATORS, PRESSURE BOOSTERS, SUBMERSIBLE PUMPS, HEAT TRANSFER EQUIPMENT, HYDRONIC SPECIALTIES, AIR CONTROL, BALANCE VALVES, ELECTRONIC CONTROL SYSTEMS, BLADDER, DIAPHRAGM & STANDARD COMPRESSION TANKS, WELL & WATER SYSTEM TANKS, THERMAL EXPANSION TANKS, SEWAGE, EFFLUENT & GRINDER PUMPS, LARGE NON-CLOG PUMPS, SELF PRIMERS & PACKAGED PUMPING SYSTEMS



G & L SERIES, WATER & MILD CORROSIVE PUMPS, 304 & 316 INVESTMENT CAST STAINLESS STEEL, END SUCTION, HORIZONTAL & VERTICAL MULTISTAGE, HIGH PRESSURE MULTI-STAGE WATER GUNS



RESIDENTIAL AND COMMERCIAL CONDENSING STAINLESS STEEL BOILERS AND WATER HEATERS, COPPER-FIN BOILERS AND WATER HEATERS, HEAT PUMP WATER HEATERS, STORAGE TANKS, HOT WATER GENERATOR SYSTEMS, BUFFER TANKS AND GAS FIRED POOL HEATERS.



PACKAGED INSTANTANEOUS & SEMI-INSTANTANEOUS INDIRECT WATER HEATERS, STEAM GENERATORS, ELECTRIC WATER HEATERS & BOILERS, CEMENT-LINED STORAGE TANKS, FLASH TANKS, BLOWDOWN TANKS, CONDENSATE COOLERS, TUBE BUNDLES



FLEXIBLE COUPLINGS, RUBBER AND METAL CONNECTORS, METRALOOP EXPANSION LOOPS, HYDRO-FORMED EXPANSION JOINTS, EXPANSION COMPENSATORS, PIPE ALIGNMENT GUIDE, WALL PENETRATIONS SEALS, BUTTERFLY VALVES, PIPELINE STRAINERS, FM AND UL RATINGS



CONDENSATE TRANSFER & BOILER FEED PUMPS, VACUUM PUMPS, CONTROL SYSTEMS



STEAM SPECIALTIES, TEMPERATURE & PRESSURE CONTROL VALVES, STEAM TRAPS, AUTOMATIC & MANUAL AIR VENTS, VACUUM BREAKERS, CONDENSATE & BOILER FEED PUMPS



McDonnell & Miller

BOILER SAFETY CONTROLS, LIQUID LEVEL CONTROLS, FLOW SWITCHES



MADE IN USA AND GSA CERTIFIED PRESSURE INDEPENDENT CONTROL VALVES, ACTUATED BALL VALVES, MANUAL BALANCE VALVES, AUTOMATIC BALANCE VALVES, COIL PIPING PACKAGES, HOSE KITS AND PIPING COMPONENTS & ACCESSORIES



ASME CERTIFIED AND NON-ASME CERTIFIED PRESSURE VESSELS



PACKAGED SYSTEMS FOR PUMPING AND HEAT TRANSFER APPLICATIONS

- | | |
|-------------------------|---|
| BOILERMAG | • MAGNETIC FILTERS FOR HEATING AND COOLING SYSTEMS |
| CORCORAN | • EXOTIC MATERIAL CENTRIFUGAL PUMPS |
| DANFOSS | • ZONE CONTROL PANELS, MIXING & ZONE VALVES, DIGITAL THERMOSTATS |
| FLOW CONDITIONING CORP. | • DOUBLE SUCTION DIFFUSERS, HYDRONIC INDICATORS |
| HOLBY VALVE | • TEMPERATURE REGULATING VALVES |
| J.L. WINGERT | • CHEMICAL FEEDERS, SEPARATORS |
| PETERSON EQUIPMENT | • PETE'S PLUG PRESSURE & TEMPERATURE TEST STATIONS |
| REFRIGERATION RESEARCH | • REFRIGERATION SUCTION ACCUMULATORS & RECEIVERS, HEAT EXCHANGERS, FILTER-DRIERS, MUFFLERS, SPECIALTIES |
| SLANT FIN | • SECTIONAL CAST IRON BOILERS, BASEBOARD RADIATION |
| MILJOCO CORP. | • GAUGES, THERMOMETERS |



ECOVIE
Water Management Systems

AQUALOOP

**CITY OF L.A. AND
L.A. COUNTY APPROVED!**

Greywater Recycling



Solving water scarcity and quality problems one building at a time

Our water challenges are solvable!

- Rain water collection
- Grey water recycling
- Storm water management



High performance, easy to maintain and durable products and services with strong water management

AQUALOOP

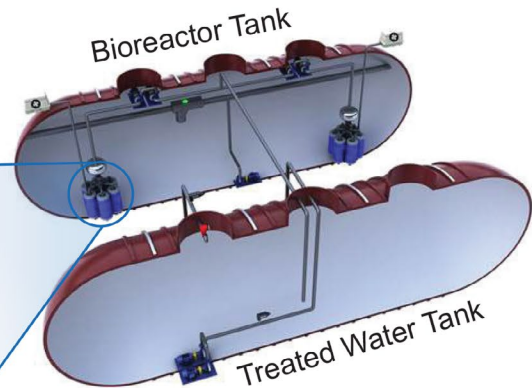

Certified to
NSF/ANSI 350

- Patented Membrane
- Simplified MBR Technology
- Low Maintenance
- No Added Chemicals
- Scalable
- Remote Monitoring

SERVING THE BUILDING TRADES SINCE 1962



weil aquatronics
Treating Water as a Resource™

13630 San Antonio Drive
Norwalk, California 90650

www.weilaquatronics.com

Tel: 562.364.7430

Fax: 562.474.1327

info@weilaquatronics.com

**CALL TOLL FREE:
800.74PUMPS
(800.747.8677)**



info@enviroproductswest.com

SOUTHERN CALIFORNIA LINE CARD (888) 959-2937

ENVIRONMENTAL PRODUCTS



Xerxes

High Volume Fiberglass Grease Interceptor
Oil Water Separators & Storm Water Tanks



Grease Guardian

Point of Source Grease Removal Device



FogEnforcer

Ultra High Super Capacity Grease Interceptors

PUMPS, PUMP SYSTEMS & CONTROLS



Armstrong Fire Pumps



Ebara

FM Cast Iron & CSA Stainless Steel Pumps



Goulds Pumps

CSA Cast Iron & Stainless Steel Pumps



Landia

Cutter Pumps Submersible & Vertical Column



Tramco Pumps

Vertical Column Sump & Sewage Pumps



Topp Industries

Fiberglass Basins, Packaged Lift Stations



VC Systems

NSF/ANSI 61 & 372 Booster Systems

ACCESSORIES

U.L. LISTED CONTROL PANELS
FIBERGLASS BASINS
FABRICATED STEEL PRODUCTS

LEVEL CONTROLS & FLOATS
ELEVATOR ALARMS SYSTEMS
HYDRO-PNEUMATIC TANKS

Contact Us

ASPE Orange County
 179 S. Barbara Way, Anaheim, CA 92806
 Phone (714) 305-9015
 E-Mail chrismacknight857@msn.com
 Web www.aspec.com

2018 - 2019 ASPE OC CHAPTER BOARD MEMBERS

Board of Directors



John Patterson
 President
 (818) 207-0912



Kurt Bramstedt
 Region 4 Affiliate Liaison
 Rheem Commercial Water Heating
 (657) 274-5686



Saum Nour
 Vice President – Legislative
 Absolute Consulting Engineers
 (949) 852-8700



Alex Jimenez
 Vice President – Membership
 Delco Sales
 (909) 203-2008

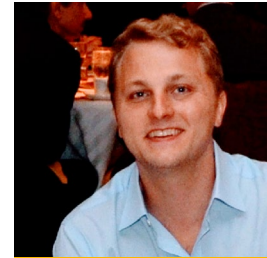

Eric Decker
 Vice President - Legislative
 Dawson Company
 (909) 762-0924



Jim Weil
 Administrative Secretary
 Weil Aquatronics
 (714) 679-9514

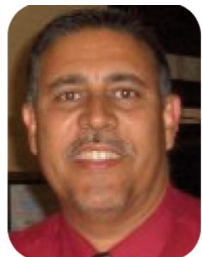

Roland Gutierrez
 Corresponding Secretary
 Dawson Co.
 (626) 429-9307



Bob Woods
 Treasurer
 Raypak
 (818) 292-1538



Ira Schumer
 Affiliate Liaison
 Signature Sales
 (951) 691-0568



In the next issue...